



WARNING - Reliance on this Manual Could Result in Severe Bodily Injury or Death!

This manual is out-of-date and is provided only for its technical information, data and capacities. Portions of this manual detailing procedures or precautions in the operation, inspection, maintenance and repair of the product forming the subject matter of this manual may be inadequate, inaccurate, and/or incomplete and cannot be used, followed, or relied upon. Contact Conair at info@conairgroup.com or 1-800-654-6661 for more current information, warnings, and materials about more recent product manuals containing warnings, information, precautions, and procedures that may be more adequate than those contained in this out-of-date manual.

User Guide

Installation

Operation

Maintenance

Troubleshooting

SC Mobile Drying and Conveying Unit

Models SC-MDC 7.5, 15, 30 and 60

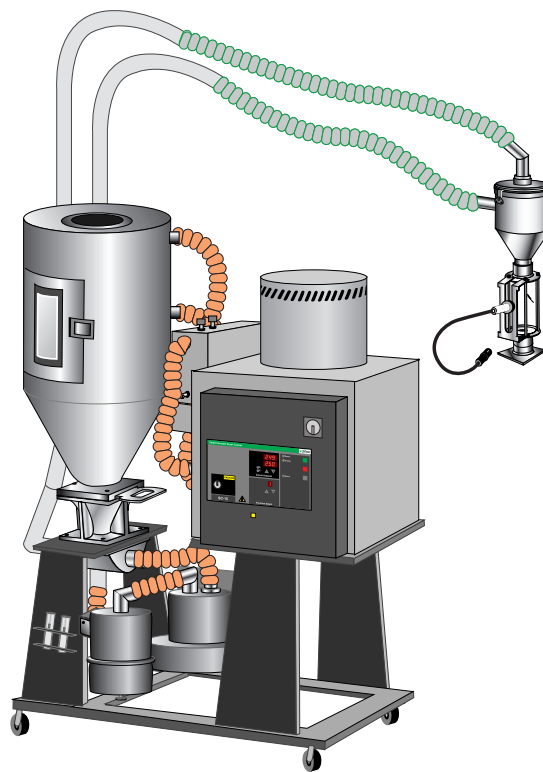

**Instant Access
Parts and Service**
(800) 458-1960
(814) 437-6861

www.conairnet.com

CONAIR™

The Conair Group, Inc.
One Conair Drive
Pittsburgh, PA 15202
Phone: (412) 312-6000
Fax: (412)-312-6227

UGD017/0700

Please record your equipment's model and serial number(s) and the date you receive it in the spaces provided.

It's a good idea to record the model and serial number(s) of your equipment and the date you received it in the User Guide. Our service department uses this information, along with the manual number, to provide help for the specific equipment you installed.

Please keep this User Guide and all manuals, engineering prints and parts lists together for documentation of your equipment.

Date:
Manual number: UGD017/0700
Serial number(s):
Model number(s):

DISCLAIMER: The Conair Group, Inc., shall not be liable for errors contained in this User Guide or for incidental, consequential damages in connection with the furnishing, performance or use of this information. Conair makes no warranty of any kind with regard to this information, including, but not limited to the implied warranties of merchantability and fitness for a particular purpose.

TABLE OF CONTENTS

INTRODUCTION	1-1
Purpose of the user guide	1-2
How the guide is organized	1-2
Your responsibilities as a user	1-2
ATTENTION: Read this so no one gets hurt	1-3
How to use the lockout device.....	1-5
DESCRIPTION	2-1
What is the SC-MDC?.....	2-2
Typical applications	2-2
How the dryer works	2-3
How conveying works	2-3
Specifications: SC-MDC	2-5
INSTALLATION.....	3-1
Unpacking the boxes.....	3-2
Preparing for installation	3-3
Installing the SC-MDC.....	3-4
Connecting the conveying lines.....	3-5
Connecting the RTD probe.....	3-6
Connecting the demand sensor.....	3-6
Connecting the main power.....	3-7
Connecting water lines	3-7
Testing the installation.....	3-8
OPERATION.....	4-1
The SC-MDCr control panel	4-2
SC-MDC functions	4-3
To start drying.....	4-4
To stop drying	4-5
Using the Auto Start Timer.....	4-5
Setting high and low setpoint limits	4-6
To stop conveying	4-5
To stop conveying	4-5
Transporting the SC-MDC	4-6
MAINTENANCE.....	5-1
Preventative maintenance checklist	5-2
Cleaning the hopper.....	5-3
Cleaning the conveying lines.....	5-4
Cleaning the K Loader.....	5-4
Cleaning the dust collector	5-5
Cleaning the process filter	5-6
Cleaning the regeneration filter	5-6
Cleaning the aftercooler coils.....	5-6
Inspect hoses and gaskets	5-7

TABLE OF CONTENTS

TROUBLESHOOTING..... 6-1

Before beginning.....6-2

A few words of caution6-2

DIAGNOSTICS

How to identify the cause of a problem6-3

Dryer will not power up6-4

Shut down alarms6-4

Err 016-4

Err 026-5

Err 036-6

Err 04, 05 and 06.....6-7

Err 07 and 086-8

Passive alarms6-9

Err 096-9

Err 106-10

Err 11 and 126-11

Err 136-12

REPAIR

Checking motor overloads6-14

Replacing fuses6-15

Checking heater contactors.....6-15

Checking or replacing temperature sensors.....6-16

Adjusting the demand sensor.....6-17

Adjusting the limit switch6-18

Replacing heater elements6-19

Replacing desiccant tanks.....6-20

Refilling desiccant tanks.....6-21

Adding an aftercooler6-22

APPENDIX

Service/Warranty informationAppendix A

Material Safety Data SheetsAppendix B

If you purchased an SC dryer option, instructions
can be found in the appendix.

Option: SPI communicationAppendix C

PARTS/DIAGRAMS

This section has been provided for you to
store spare parts lists and diagrams.

INTRODUCTION

- *Purpose of the User Guide1-2*
- *How the guide is organized1-2*
- *Your responsibilities as a user ...1-2*
- *ATTENTION: Read this so
no one gets hurt1-3*
- *How to use the lockout device ..1-5*

PURPOSE OF THE USER GUIDE

This User Guide describes the Conair SC series of mobile drying and conveying units and explains step-by-step how to install, operate, maintain and repair this equipment.

Before installing this product, please take a few moments to read the User Guide and review the diagrams and safety information in the instruction packet. You also should review manuals covering associated equipment in your system. This review won't take long, and it could save you valuable installation and operating time later.

HOW THE GUIDE IS ORGANIZED

Symbols have been used to help organize the User Guide and call your attention to important information regarding safe installation and operation.



Symbols within triangles warn of conditions that could be hazardous to users or could damage equipment. Read and take precautions before proceeding.



Numbers within shaded squares indicate tasks or steps to be performed by the user.



A diamond indicates the equipment's response to an action performed by the user.



An open box marks items in a checklist.



A shaded circle marks items in a list.

YOUR RESPONSIBILITY AS A USER

You must be familiar with all safety procedures concerning installation, operation and maintenance of this equipment. Responsible safety procedures include:

- Thorough review of this User Guide, paying particular attention to hazard warnings, appendices and related diagrams.
- Thorough review of the equipment itself, with careful attention to voltage sources, intended use and warning labels.
- Thorough review of instruction manuals for associated equipment.
- Step-by-step adherence to instructions outlined in this User Guide.

We design equipment with the user's safety in mind. You can avoid the potential hazards identified on this machine by following the procedures outlined below and elsewhere in the User Guide.

 **ATTENTION:**
READ THIS SO NO
ONE GETS HURT



WARNING: High voltage

This equipment is powered by single- or three-phase main voltage. Always disconnect and lock out the main power source before servicing. To help you, we've equipped the dryer with a lockable, electrical disconnect device. You are responsible for developing a lockout procedure.



CAUTION: Hot Surfaces

Always protect yourself from hot surfaces inside the dryer and hopper. Also exercise caution around certain exterior surfaces that can reach temperatures of 180° to 200° F (82° to 93° C). These include the hopper door frame, the exterior of an uninsulated hopper, the return air hose and the dryer's process filter housing and moisture exhaust outlet.



WARNING: Do not place aerosol, compressed gas or flammable materials on or near this equipment.

The hot temperatures associated with the drying process may cause aerosols or other flammable materials placed on the dryer or hopper to explode.



WARNING: Hazardous substance

The electrical contactors in this dryer contain mercury, which is considered a hazardous substance and must be dealt with accordingly. Material Safety Data Sheet (#7439-97) has been included in your instruction packet. This sheet explains the potential hazards, how to avoid them and how to clean up and dispose of the mercury if it spills.



ATTENTION:
READ THIS SO NO
ONE GETS HURT



CAUTION: Wear eye protection

Always wear eye protection when working around the K Loader during operation. Under certain conditions, overheated and decomposing resin in a processing machine can create pressure that could rupture the viewing chamber sight glass.

⚠ CAUTION: Before performing maintenance or repairs on this product, you should disconnect and lock out electrical power sources to prevent injury from unexpected energization or start-up. A lockable device has been provided to isolate this product from potentially hazardous electricity.

HOW TO USE THE LOCKOUT DEVICE

Lockout is the preferred method of isolating machines or equipment from energy sources. Your Conair product is equipped with the lockout device pictured below. To use the lockout device:



1 Stop or turn off the equipment.

2 Isolate the equipment from electrical power. Turn the rotary disconnect switch to the Off, or **O** position.

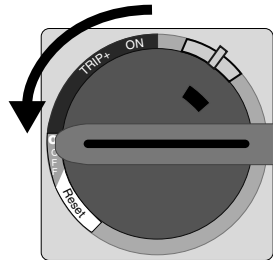

3 Secure the device with an assigned lock or tag. Pull out the center tab of the rotary handle. Insert a lock or tag in the holes to prevent movement.

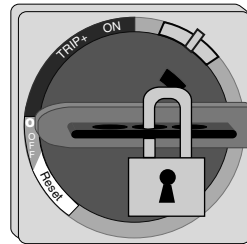

4 The equipment is now locked out.

⚠ WARNING: Before removing lockout devices and returning switches to the ON position, make sure that all personnel are clear of the machine, tools have been removed and all safety guards reinstalled.

To rotate the disconnect back to the On position:

1 Remove the lock or tag and push in the center tab of the rotary handle.

2 Slide the spring tab down.

3 Turn the rotary disconnect switch to the ON or I position.

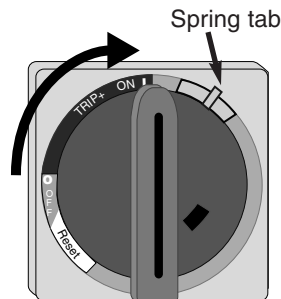

DESCRIPTION

- *What is the SC-MDC? 2-2*
- *Typical applications 2-2*
- *How the dryer works 2-3*
- *How conveying works 2-4*
- *Specifications: SC Dryer 2-5*
- *Specifications: CH hoppers 2-6*
- *Specifications: Main power
supply wire 2-6*

WHAT IS THE SC-MDC?

The SC-MDC is a self-contained, mobile unit designed to dry plastic resin and convey it with dehumidified air directly to a processing machine. This mobile unit contains the:

- SC Carousel Dehumidifying Dryer
- Drying hopper and material distribution box
- Conveying blower and dust collector
- Mobile drying cart
- K Loader direct feed vacuum receiver and demand sensor
- Quick disconnect conveying hoses

The SC dryer produces hot, low-dew point air that removes moisture from hygroscopic plastics. When the conveying function is turned on, the conveying blower conveys the dried resin to the K Loader mounted on the processing machine. The demand sensor on the K Loader viewing chamber allows you to convey just enough material to satisfy the shot size required for your process.

TYPICAL APPLICATIONS

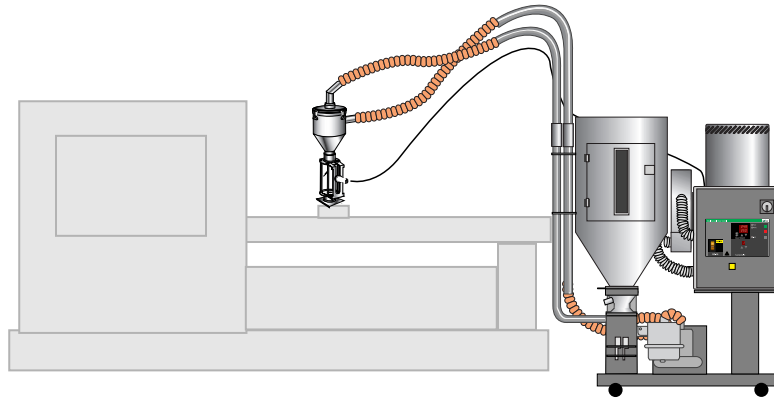

The SC-MDC was designed for drying and conveying beside the press. But it can also be used to pre-dry material in one location, and then transport the dried material to another location for conveying into the processing machine.

The SC-MDC can be used successfully in applications that require:

- A contamination-free drying environment.
- Drying temperatures of 150° to 375° F (66° to 191° C).
- Throughput rates of 7 to 112 lbs (3.2 to 50.8 kg) per hour.
- Dew points of -40° F (-40°C).
- Conveying material at distances up to, but not more than, 8 feet (2.4 m) vertically and 6 feet (1.8 m) horizontally.

An aftercooler is required if:

- You are drying at temperatures over 250° F (121°C).
- Throughput rates are less than 50% of the dryer's rated capacity.
- You are pre-drying material at temperatures over 150° F (66° C).

NOTE: Throughput rates will vary by SC-MDC model and type of material. See the SPECIFICATION pages for recommended throughputs.

The SC Carousel Dryer achieves continuous, closed loop drying by passing air simultaneously through two heaters and three tanks of molecular sieve desiccant.

HOW THE DRYER WORKS

□ The Process (Drying) Cycle

The process blower pulls moist air from the top of the drying hopper. The air passes through the process filter and aftercooler into the dryer's desiccant tank, where moisture is removed. The now-dry air moves through the process heater, where it is heated to the drying temperature selected by the operator. The hot, dry air is delivered to the hopper, where a spreader cone evenly distributes the air through the material.

■ The Carousel

The carousel indexes every 15 minutes, moving a desiccant tank through three cycles in 45 minutes.

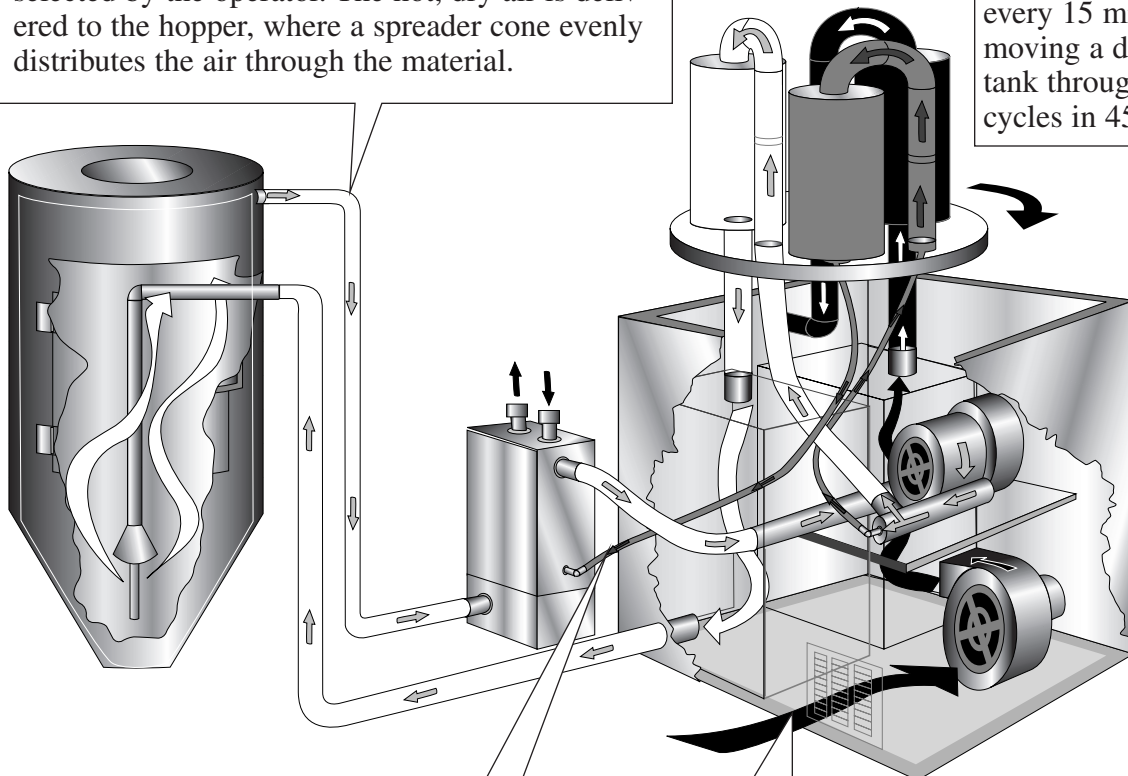

■ The Cooling Cycle

A regenerated desiccant tank must be cooled to the drying temperature range before it is moved back into the process cycle. The process blower pushes a small amount of air through the regenerated desiccant tank. The cooling air then passes through the aftercooler and repeats the circuit.

■ The Regeneration Cycle

The regeneration blower pulls air through the regeneration filter into the dryer's regeneration heater. The air is heated to 380° F (193° C) before it is pushed into the "wet" desiccant tank. The hot air purges moisture from the desiccant. The moist air is blown out the exhaust at the back of the dryer.

How CONVEYING WORKS

When the conveying function is turned on, the SC-MDC uses dry air to move material from the drying hopper to the process machine as it is needed.

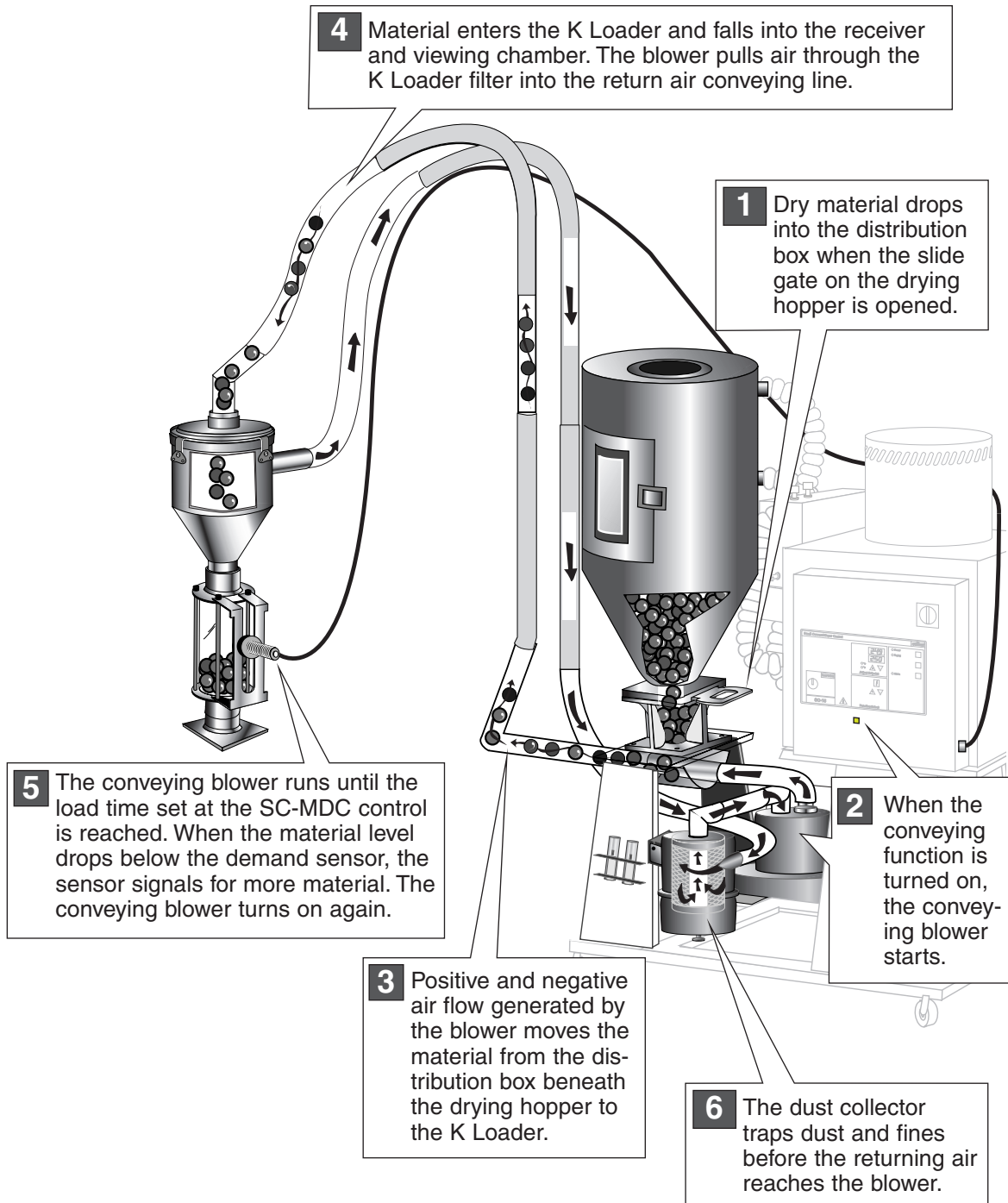

SPECIFICATIONS: SC-MDC

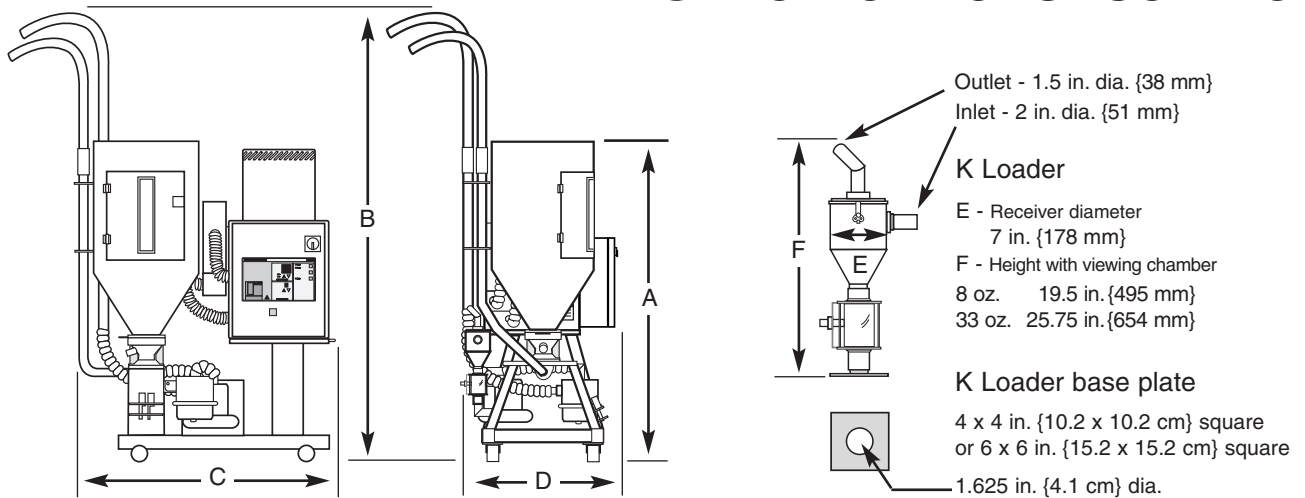

DRYER MODEL	MDC7.5-SC		MDC15-SC			MDC30-SC		MDC60-SC			
Hopper selection*	CH10-1	CH10-1.5	CH14-2	CH14-3	CH14-4	CH18-4	CH18-6	CH24-8	CH24-12	CH24-15	
Performance characteristics											
Air flow ft ³ /min {m ³ /min}	7.5 {0.21}		15 {0.4}			30 {0.85}		60 {1.7}			
Drying temperature	160° -375° F {71°-191° C}										
Dew point	-40° F {-40° C}										
Maximum conveying distance ft {m} with long-distance option	8 {2.44} vertical; 6 {1.83} horizontal 15 {4.57} vertical; 50 {15.24} horizontal										
Dimensions inches {cm}											
A - Height to top of hopper	69 {175.3}	80 {203.2}	71 {180.3}	82 {208.3}	93 {236}	74 {188.0}	94 {238.8}	88 {223.5}	103 {261.6}	117 {297.2}	
B - Total height	100 {254.0}	100 {254.0}	100 {254.0}	100 {254.0}	100 {254.0}	100 {254.0}	100 {254.0}	100 {254.0}	103 {261.6}	117 {297.2}	
C - Width	38 {96.5}	38 {96.5}	38 {96.5}	38 {96.5}	38 {96.5}	44.5 {113.0}	44.5 {113.0}	58 {147.3}	58 {147.3}	58 {147.3}	
D - Depth	27.5 {69.9}	27.5 {69.9}	27.5 {69.9}	27.5 {69.9}	27.5 {69.9}	28.5 {72.4}	28.5 {72.4}	31 {78.7}	31 {78.7}	31 {78.7}	
Weight lb {kg}											
Shipping	590 {268}	600 {272}	650 {29.5}	660 {299}	670 {304}	785 {356}	805 {365}	1025 {465}	1055 {478}	975 {442}	
Voltages Total amps											
	STANDARD		LONG DIST.		STANDARD		LONG DIST.		STANDARD		LONG DIST.
208V/3 phase/60 Hz	12.8	15.8	15.3	19.1	19.7	23.7	31.6	—			
240V/3 phase/60 Hz	10.8	14.3	13.7	17.2	17.6	21.1	28.1	29.9			
380 or 415V/3 phase/50 Hz	7.6 / 7.9	10.0/10.5	10.8/11.3	13.2/13.5	11.4/11.1	13.8/13.3	17.2/15.7	19.6/17.9			
480V/3 phase/60 Hz	6.3	8.1	10.0	11.8	9.0	10.8	14.2	16.0			
575V/3 phase/60 Hz	5.3	6.9	6.8	8.5	7.9	9.6	11.5	13.1			
Total kilowatts	4.8 kW	5.7 kW	5.7 kW	6.5 kW	7.1 kW	7.9kW	11.1 kW	11.9 kW			
Water requirements {for optional aftercooler}											
Recommended temperature [†]	70°-90° F {21°-32° C}										
Water flow gpm {liters/min.}	3 {11.36} / 1/2 inch NPT female fittings										

RECOMMENDED THROUGHPUTS[‡]						
MATERIAL TYPE	DRYING TIME {hrs}	DRYING TEMPERATURE °F {°C}	MODEL MDC7.5-SC lbs/hr {kg/hr}	MODEL MDC15-SC lbs/hr {kg/hr}	MODEL MDC30-SC lbs/hr {kg/hr}	MODEL MDC60-SC lbs/hr {kg/hr}
PET	4-6	300-350 {149-177}	7.5 {3.4}	15 {6.8}	30 {13.6}	60 {27.2}
PBT	2-4	250 {121}	7.5 {3.4}	15 {6.8}	30 {13.6}	60 {27.2}
PC	3-4	250 {121}	10 {4.54}	20 {9.07}	40 {18.14}	80 {36.28}
Cellulosics	6	160 {71}	10 {4.54}	20 {9.07}	40 {18.14}	80 {36.28}
PETG	4-6	150 {66}	10 {4.54}	20 {9.07}	40 {18.14}	80 {36.28}
Polyester	3	225 {107}	10 {4.54}	20 {9.07}	40 {18.14}	80 {36.28}
PU	3	180 {82}	10 {4.54}	20 {9.07}	40 {18.14}	80 {36.28}
Nylon	6	160 {71}	11.5 {5.22}	23 {10.43}	46 {20.86}	92 {41.72}
ABS	3.5	180 {82}	12.5 {5.67}	25 {11.34}	50 {22.68}	100 {45.36}
Acrylic	2	160-180 {71-82}	13.5 {6.12}	27 {12.25}	54 {24.5}	108 {49.0}
Acetal	2	210 {99}	14 {6.35}	28 {12.7}	56 {25.4}	112 {50.8}

SPECIFICATION NOTES:
* Consult Conair about other available hopper selections.
† Temperatures above or below the recommended levels may affect dryer performance. Tower, chiller or municipal water sources can be used.
‡ Throughputs will vary by type of material. Consult Conair about throughput for materials that are not listed here.
Specifications may change without notice. Check with a Conair representative for the most current information.

SPECIFICATIONS: CH DRYING HOPPERS

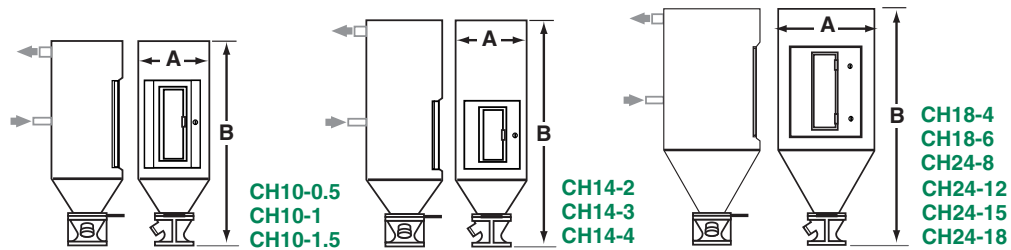

MODEL	CH10-0.5	CH10-1	CH10-1.5	CH14-2	CH14-3	CH14-4
Performance characteristics						
Capacity ft ³ {liter}	0.5 {14}	1.0 {28}	1.5 {42}	2 {57}	3 {85}	4 {113}
Capacity @ 35 lb/ft ³	18	35	53	70	105	140
Dimensions inches {cm}						
A - Inside diameter	10 {25}	10 {25}	10 {25}	14 {36}	14 {36}	14 {36}
B - Hopper height	25 {64}	39 {99}	50 {127}	41 {104}	52 {132}	58 {147}
Air inlet (OD)	1.75 {4.4}			2 {5.1}		
Air outlet (OD)	2 {5.1}			2.5 {6.4}		
Material discharge (ID)	2 {5.1}			2 {5.1}		
Weights lb {kg}						
Installed weight (hopper only)	40 {18}	50 {23}	70 {32}	80 {36}	95 {43}	110 {50}
Mounting interfaces						
Hopper loader (Top)	IT06	IT06	IT06	IT06	IT06	IT06
Material discharge (Bottom)	IB02	IB02	IB02	IB02	IB02	IB02

MODEL	CH18-4	CH18-6	CH24-8	CH24-12	CH24-15	CH24-18
Performance characteristics						
Capacity ft ³ {liter}	4 {113}	6 {170}	8 {227}	12 {340}	15 {425}	18 {509}
Capacity @ 35 lb/ft ³	525	630	140	210	280	420
Dimensions inches {cm}						
A - Inside diameter	24 {61}	24 {61}	18 {46}	18 {46}	24 {61}	24 {61}
B - Hopper height	85 {216}	100 {254}	44 {112}	64 {163}	60 {152}	73 {185}
Air inlet (OD)	2.5 {6.4}		2.5 {6.4}		2.5 {6.4}	
Air outlet (OD)	3 {7.6}		3 {7.6}		3 {7.6}	
Material discharge (ID)	2.5 {6.4}		2 {5.1}		2.5 {6.4}	
Weights lb {kg}						
Installed weight (hopper only)	240 {109}	250 {113}	145 {66}	170 {77}	210 {95}	230 {104}
Mounting interfaces						
Hopper loader (Top)	IT07	IT07	IT07	IT07	IT07	IT07
Material discharge (Bottom)	IB02	IB02	IB02	IB02	IB02	IB02

SPECIFICATIONS: MAIN POWER SUPPLY WIRE

The main power wire must be:

- Grounded and secured with a strain relief.
- Correctly sized for the current drawn.

Allowable ampacities of Copper Conductors					
Conductor Size AWG	U.S.A.		Ground wire Size AWG	European Community	
	75°C insulation 30°C ambient air	Canada 90°C insulation 40°C ambient air		70°C insulation; 40°C ambient air	Conductor Size mm ²
14	15	13	14	2,5	16
12	20	17	12	4	23
10	30	27	10	6	29
8	43	47	10	10	40

NOTE: Local or regional electrical guidelines may have specifications that differ from the above national codes. You should comply with the codes for your area.

INSTALLATION

- *Unpacking the boxes 3-2*
- *Preparing for installation 3-3*
- *Installing the SC-MDC 3-4*
- *Connecting conveying lines 3-5*
- *Connecting the RTD probe 3-6*
- *Connecting the demand sensor.. 3-6*
- *Connecting the main power 3-7*
- *Connecting water lines 3-7*
- *Testing the installation 3-8*

UNPACKING THE BOXES

The SC-MDC comes fully assembled on a mobile drying cart. You should have received the following components:

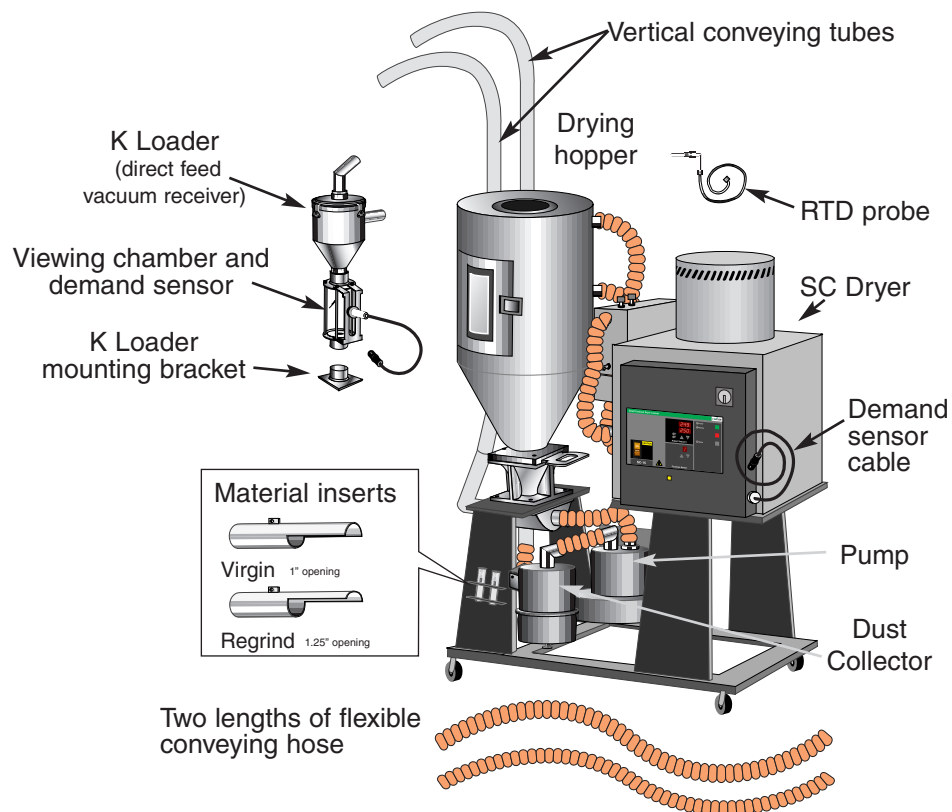

- 1 Carefully remove the dryer and components** from the shipping container. The K Loader and material inserts will be on the built-in holders on the drying cart. The RTD probe and extension cable may have been shipped inside the dryer's electrical enclosure.
- 2 Remove all packing material**, protective paper, tape and plastic. Be sure to remove the plastic tie and wrap that protects the desiccant tank and bed plate assembly during shipment.
- 3 Carefully inspect all components** to make sure no damage occurred during shipping, and that you have all the necessary hardware.
- 4 Take a moment to record serial numbers** and electrical power specifications in the blanks provided on the back of the the User Guide's title page. The information will be helpful if you ever need service or parts.
- 5 You are now ready to begin installation.** Follow the preparation steps on the next page.

The SC-MDC has been designed for use beside the processing machine. The mobile unit also can be used for pre-drying in a remote location.

PREPARING FOR INSTALLATION

1 Make sure the location for the MDC provides:

- ❑ **A grounded power source supplying the correct current** for your dryer model. Check the dryer's serial tag for the correct amps, voltage, phase and cycles. Field wiring should be completed by qualified personnel to the planned location for the dryer. All electrical wiring should comply with your region's electrical codes.
- ❑ **A source of water, if you have an aftercooler.** The SC dryer's optional aftercooler can use tower or city water at temperatures of 70° to 90° F (21° to 32° C). Pipe should be run to the planned dryer location. Use flexible hose to connect the water pipes to the aftercooler.
- ❑ **Minimum clearance for safe operation and maintenance.** The SC-MDC should not be placed near flammable or combustible materials during operation. We recommend at least 25 inches (63.5 cm) clearance above the dryer for removing the carousel housing. You will need at least 24 inches (61 cm) clearance on any side of the SC-MDC for access to components that need cleaning or servicing.

2 Mount the K Loader mounting bracket.

Lay out the bolt pattern of the processing machine feed throat on the blank base plate of the K Loader mounting bracket and gasket. Drill holes for the mounting bolts you plan to use. Place the gasket between the feed throat and mounting bracket. Bolt the mounting bracket to the feed throat.

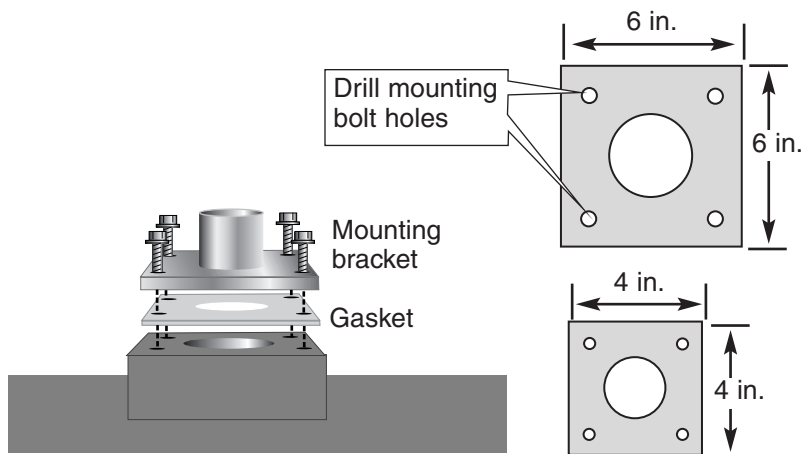

NOTE: You will receive a 4"x4" or 6"x6" mounting bracket, as specified in your order. If you need a larger mounting bracket, call your Conair sales representative.

INSTALLING THE SC-MDC

The SC-MDC was designed to be mobile. So everytime you move the SC-MDC, you will need to mount the K Loader, connect the main power source and connect a water source for the optional aftercooler.

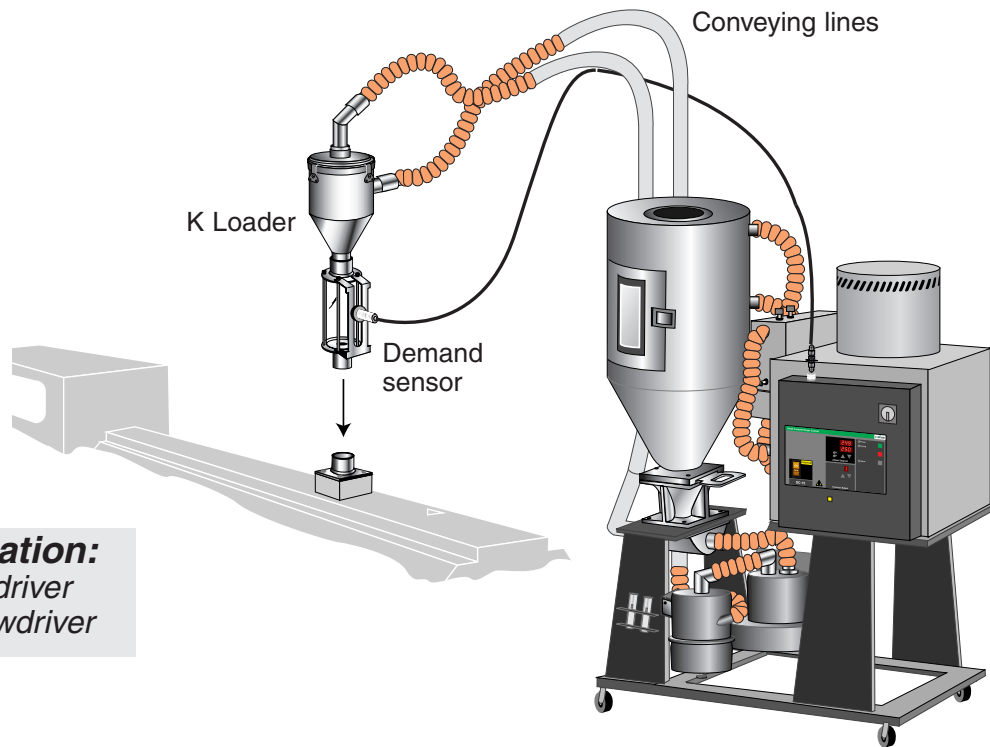

Tools for installation:

- Phillips screwdriver
- Flathead screwdriver

The first time you install the SC-MDC:

- 1** Move the SC-MDC to the processing area.
Lock the wheels on the drying cart.
- 2** Mount the K Loader on the feed throat.
Push the K Loader onto the mounting bracket.
- 3** Connect the conveying lines.
- 4** Connect the RTD probe.
- 5** Connect the demand sensor to the electrical enclosure of the dryer.
- 6** Connect the main power source.
- 7** Connect a source of water for the optional aftercooler.

The vertical conveying tubes and flexible conveying hoses may have been removed for shipping. To assemble:

CONNECTING CONVEYING LINES

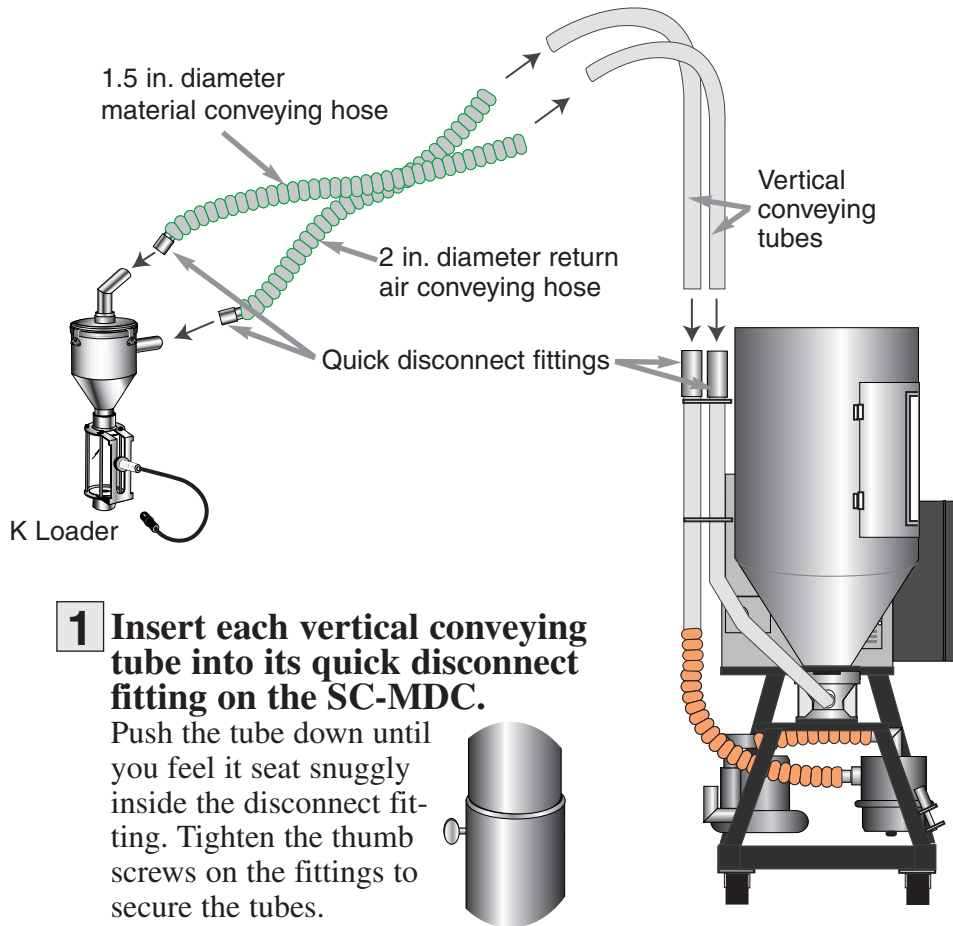

1 Insert each vertical conveying tube into its quick disconnect fitting on the SC-MDC.

Push the tube down until you feel it seat snugly inside the disconnect fitting. Tighten the thumb screws on the fittings to secure the tubes.

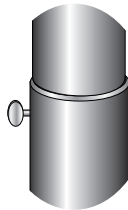

2 Secure flexible conveying hoses to the vertical tubes with hose clamps. Insert the tube at least 1 inch (2.54 cm) into the flexible hose. Secure the hose clamp at least 1/4 in. (.64 cm) from the end of the tube.

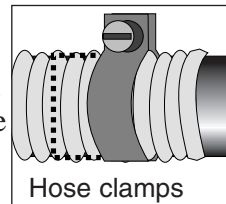

3 Attach the flexible conveying hoses to the appropriate inlet and outlet of the K Loader.

Push the quick disconnect fitting on the material conveying hose over the material inlet tube. Push the quick disconnect fitting on the return air conveying hose over the conveying air outlet of the K Loader. Tighten the thumb screws on the fitting.

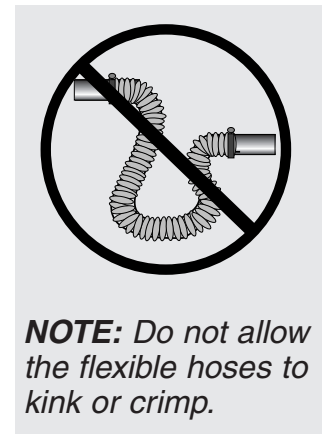
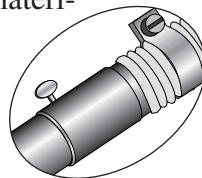

CONNECTING THE RTD PROBE

The RTD probe monitors the temperature of the drying air as it enters the hopper. If the probe is not installed correctly, temperature readings will be inaccurate.

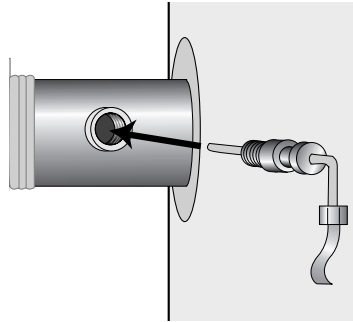

- 1** Insert the probe in the delivery air inlet at the top of the hopper. The end of the probe must not touch the walls of the inlet. Tighten the nuts to lock the probe in place.

- 2** Plug the probe's cable into the receptacle on the side of the electrical enclosure. Hand tighten the connector. Coil excess cable and secure with a wire tie.

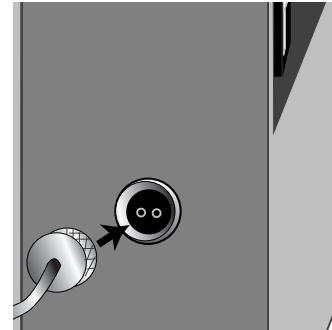

CONNECTING THE DEMAND SENSOR

The capacitive demand sensor monitors the level of material in the viewing chamber of the K Loader when the SC-MDC is conveying. The sensor signals the SC-MDC control to start the conveying blower whenever the level of material drops below the amount that you want to maintain at the feed throat.

- 1** Plug the sensor cable into the multi-pin connector on the side of the SC-MDC electrical enclosure.

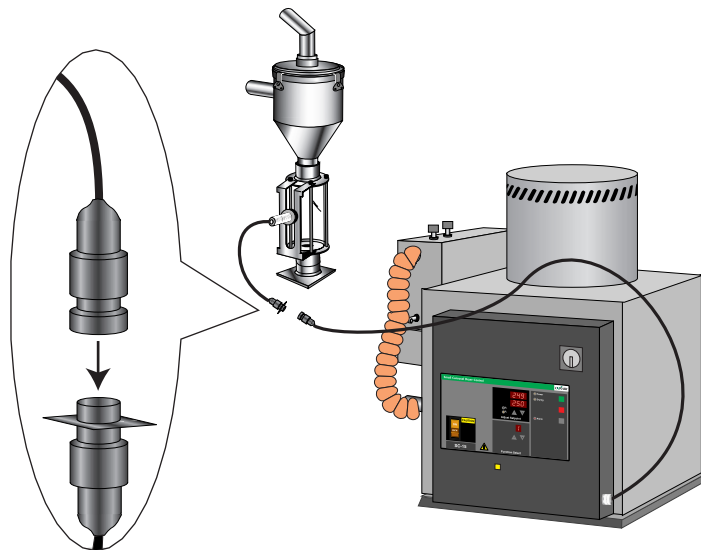

TIP: Prevent damage to the demand sensor cable by attaching it to the return air conveying line with a wire tie. Do **not** tie the cable to the smaller-diameter material conveying line. Material passing through the line will generate static electricity and noise in nearby electrical cables.



CAUTION: Always disconnect and lock out the main power sources before making electrical connections. Electrical connections should be made only by qualified personnel.

CONNECTING THE MAIN POWER



1 Open the dryer's electrical enclosure.

Turn the disconnect dial on the dryer door to the Off position. Lock out the main power. Turn the captive screw, and swing the door open.

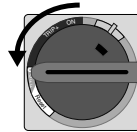

2 Insert the main power wire through the knockout in the side of the enclosure. Secure the wire with a rubber compression fitting or strain relief.

3 Connect the power wires to the three terminals at the top of the power disconnect holder.

4 Connect the ground wire to either grounding point shown in the diagram.

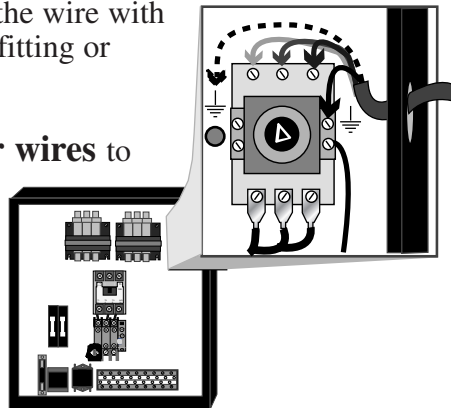

IMPORTANT: Always refer to the wiring diagrams that came with your dryer before making electrical connections. The diagrams show the minimum size main power cable required for your dryer, and the most accurate electrical component information.

The optional aftercooler requires a source of cooling water and a discharge or return line. The water source should provide 3 gallons (11.36 liters) per minute at temperatures up to 90° F (32° C).

CONNECTING WATER LINES

1 Connect the cooler inlet to the water source.

2 Connect the cooler outlet to a discharge or return line.

TIP: Make the connections with flexible hose at least 14 inches (35.5 cm) long. This allows you to easily remove the cooler coils for cleaning.



1/2 inch NPT female couplings. If a manual shut off valve is used, it should be mounted on the inlet line.

MOUNTING A LOADER ON THE HOPPER

If you have a Conair loader or vacuum receiver, you can use the flange and mounting clips provided on the top of the hopper. Refer to the manuals that came with your receiver or loader for detailed installation instructions.

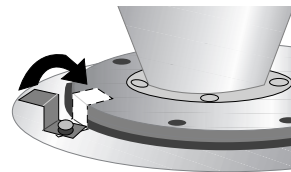

TESTING THE INSTALLATION

You have completed the installation. Now it's time to make sure everything works.

1 **Make sure there is no material in the hopper.**
If you have mounted a loader or vacuum receiver on the hopper, disconnect the material inlet hose at the source.

2 **Turn on main power to the dryer.**
Make sure the dryer's disconnect is in the on position.

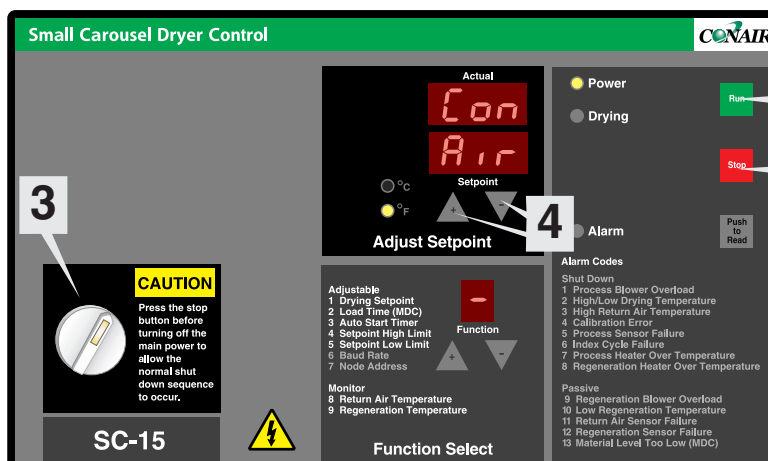
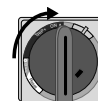

3 **Turn the power switch to the ON position.**

If everything is installed correctly:

- ◆ The power switch and power light illuminate.
- ◆ The Actual and Setpoint windows briefly display ConAir, then change to the actual temperature and a setpoint temperature of 150° F (65° C).
- ◆ The Function Select display changes from – to 1.

4 **Set the drying temperature.**

Press Adjust Setpoint ▲ or ▼ arrow until the setpoint temperature you want appears in the setpoint display.

5 **Press the RUN button.**

If everything is installed correctly:

- ◆ The amber drying light turns on.
- ◆ Process and regeneration blowers and heaters turn on.
- ◆ If the desiccant tanks are not in the correct position, the carousel will turn and stop in the correct position.

TESTING THE INSTALLATION

6 Check for proper air flow.

Remove the delivery air hose on the dryer. Hold your hand near the outlet with the dryer on. You should feel air blowing out of the dryer.



CAUTION: Hot surface

Do not place your hand on the delivery air outlet. The outlet and the air can get hot enough to burn your hand.

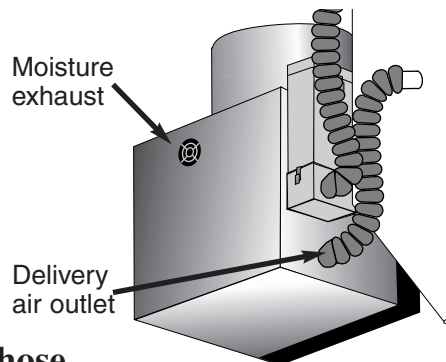

7 Replace the delivery air hose.

- ◆ The Actual display on the control should indicate higher temperatures as the delivery air sensor detects heat made by the dryer.

8 Press the STOP button.

- ◆ The amber drying light turns off, but the blowers will continue running as needed to cool the heaters.

9 Press the CONVEYING ON/OFF button.

- ◆ The conveying blower turns on.

10 Check for proper conveying air flow.

Remove the material conveying hose on the K Loader. Hold your hand near the outlet with conveying on. You should feel air blowing out of the hose.

11 The test is over.

If the dryer performed the normal operating sequences as outlined, you can begin operation. If it did not, refer to the TROUBLESHOOTING section of the User Guide.

INSTALLATION NOTE: Models SC30 and SC60

These models use a three-phase process blower. If the dryer shuts down with an Err 02 alarm condition within the first few minutes of operation, check for proper air flow.

If air flow is reversed, the process blower is turning in the wrong direction. Turn off and lock out the main power source. Open the control enclosure and reverse any two leads connecting the main power supply to the dryer.

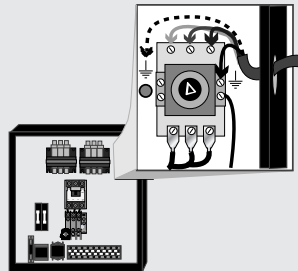

OPERATION

- *The SC-MDC control panel 4-2*
- *SC-MDC functions 4-3*
- *To start drying 4-4*
- *To stop drying 4-5*
- *Using the Auto Start Timer 4-5*
- *Setting high and low
setpoint limits 4-6*
- *To start conveying 4-7*
- *To stop conveying 4-8*
- *Transporting the SC-MDC 4-8*

THE SC-MDC CONTROL PANEL

Run/Stop Buttons
 Press RUN to start drying.
 Press STOP to stop drying.

Display windows
 The upper window displays the actual temperature of drying air entering the hopper. The lower window displays setpoint values. When there is an alarm, the windows display error codes.

Status Lights

- Power = On when the control has power.
- Drying = On when the dryer is running.
- Alarm = On when the dryer detects a problem.

C° / F° Light
 The light indicates whether temperatures are displayed in degrees Fahrenheit or degrees Celsius.

CAUTION
 Press the stop button before turning off the main power to allow the normal shut down sequence to occur.

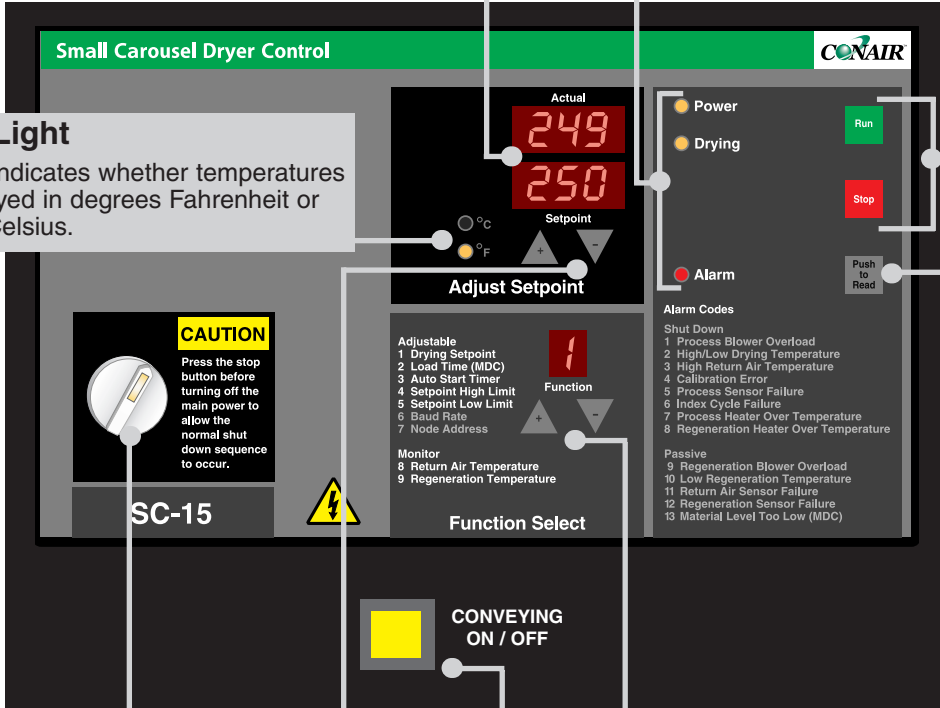

Power On/Off
 Turn the switch to turn on power to the control. Turn the switch the other direction to turn power off. The switch will light when power is on.

Function Select
 Press ▲ or ▼ buttons until the number of the function you want to program or view is displayed in the function window.
NOTE: Load Time is enabled only on MDC models.

Adjust Setpoint
 Press ▲ or ▼ to set the drying temperature, the automatic start time in hours, high and low temperature limits, or SPI parameters. Press ▲ to increase a value. Press ▼ to decrease a value.
TIP: Press and hold the button for faster scrolling speed.

Conveying ON / OFF Button
 Press to begin conveying. Press again to stop conveying.

Push To Read Button
 Press to silence the optional audible alarm and display alarm codes. For a complete explanation of alarm codes, see the Troubleshooting section.

SC-MDC FUNCTIONS

Dryer functions are values that you can set or monitor in the Actual and Setpoint display windows. Press the Function Select ▲ or ▼ buttons until the number of the function you want to set or monitor appears in the Function window.

Adjustable functions:		
No.	Function	Description
1	Drying Setpoint	Used to set the drying temperature that was recommended by the resin manufacturer.
2	Load Time (MDC)	Used to set the load time when conveying is turned on. Load time is adjustable from 3 to 15 seconds. The default is 5 seconds.
3	Auto Start Timer	Used to automatically start the dryer. The start time can be set at 1 to 150 hours from the time you entered the setpoint temperature and pushed the RUN button.
4	Setpoint High Limit	Used to prevent someone from setting the drying temperature above an acceptable level for your material. The high limit must be set at a temperature greater than or equal to the Drying Setpoint. The maximum setting is 400° F (204° C).
5	Setpoint Low Limit	Used to prevent someone from setting the drying temperature below an acceptable level for your material. The low limit must be set at a temperature less than or equal to the Drying Setpoint. The minimum setting is 100° F (38° C).
6	Baud Rate	Used to set the baud rate for SPI communication devices connected to the dryer. Baud rate = 1200, 2400, 4800 or 9600.
7	Node Address	Used to assign the dryer a network address for SPI communication. The address can be any number from 032 to 064.
Monitoring functions:		
No.	Function	Description
8	Return Air Temperature	Used to view the temperature of air returning from the drying hopper to the dryer. Lower return air temperatures indicate lower dew point and better dryer efficiency.
9	Regeneration Temperature	Used to view the temperature of air used to purge moisture from the desiccant. The regeneration setpoint of 380° F (193° C) cannot be changed. It is the optimum temperature for regenerating moisture-laden desiccant.

To START DRYING

1 Make sure there is material in the hopper.

2 Turn on the main power to the dryer. Make sure the dryer's disconnect dial is in the on position.

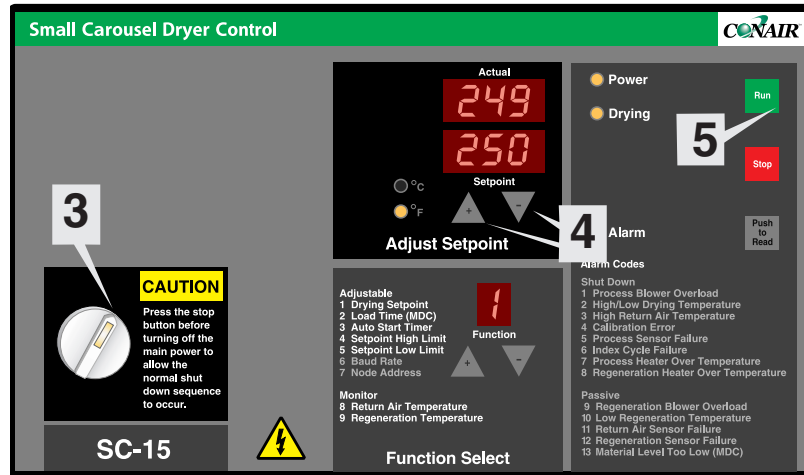
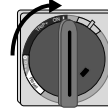

3 Turn the power switch to ON.

If everything is installed correctly:

- ◆ The Actual and Setpoint windows briefly display ConAir, then change to the actual temperature and a setpoint temperature of 150° F (65° C).
- ◆ The Function Select display changes from – to 1.



4 Set the drying temperature.

Press Setpoint Adjust ▲ or ▼ arrow until the setpoint temperature you want appears in the setpoint display.

5 Press **RUN** .

If everything is installed correctly:

- ◆ The amber drying light turns on.
- ◆ The process and regeneration blowers turn on.
- ◆ The process and regeneration heaters turn on.
- ◆ If the desiccant tanks aren't in their correct position, the carousel will turn clockwise and stop in the correct position.

To STOP DRYING

- 1 Press STOP .**
 - ◆ The drying light turns off. The blowers continue running for a few minutes to cool the heaters.
- 2 Turn the ON/OFF switch to OFF after the blowers stop running.**

Be sure to disconnect and lockout the main power if you have stopped the dryer to perform maintenance or repair.



IMPORTANT: Do **not** use the power ON/OFF switch to stop the dryer. Turning off power to the control or dryer during normal operation prevents the necessary cool-down period, and can trigger the shut down/high temperature alarm during your next drying cycle.

You can set the dryer to start automatically. The start time can be set at 1 to 150 hours from the time you entered the setpoint temperature and pushed the RUN button.

USING THE AUTO START TIMER

- 1 Make sure there is material in the hopper and power to the dryer is on.**
- 2 Set the drying temperature.**

Press Setpoint Adjust ▲ or ▼ arrow until the setpoint temperature you want appears in the setpoint display.
- 3 Select Function 3.**

Press Function Select ▲ or ▼ arrow until 3 appears in the Function display.
- 4 Enter the start time.**

Press Setpoint Adjust ▲ or ▼ arrow until you see the number of hours from now that you want the dryer to start.
- 5 Press RUN .**
 - ◆ The Actual window displays ON.
 - ◆ The amber drying light blinks to indicate that Auto Start has been enabled.
 - ◆ The dryer will begin operating when the control has finished counting down the number of hours you entered.

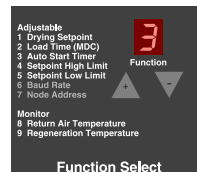
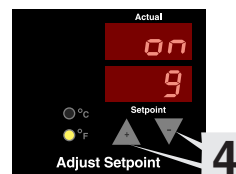
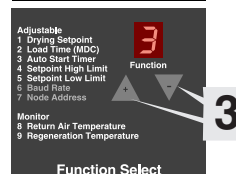
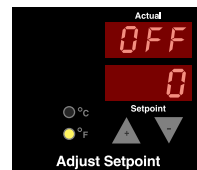

NOTE: You cannot remove or permanently deactivate the Auto Start feature to prohibit its use.

To Stop or Reprogram the Auto Start Timer:

Press **STOP** and select Function 3. Set the time to 0 to stop, or set a new start time to reprogram. Press **RUN** to resume.

SETTING LOW AND HIGH SETPOINT LIMITS

You can protect your drying process by preventing someone from entering setpoint temperatures above or below an acceptable level for the material. You can also set the high and low limits equal to the setpoint temperature to prevent accidental or unauthorized changes to the setting during operation.

1 Turn on the main power to the dryer.

2 Turn the power switch to ON.



3 Select Function 4.

Press Function Select ▲ or ▼ arrow until 4 appears in the Function display.

4 Enter the high temperature limit for setpoint.

Press Setpoint Adjust ▲ or ▼ arrow until the temperature limit you want appears in the setpoint display. The high limit must be set at a temperature greater than or equal to the drying setpoint. The maximum setting is 400° F (204° C).

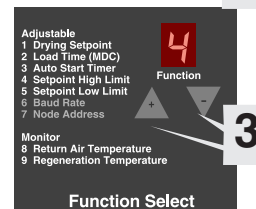
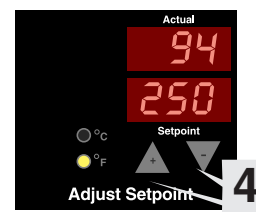

5 Select Function 5.

Press Function Select ▲ or ▼ arrow until 5 appears in the Function display.

6 Enter the low temperature limit for setpoint.

Press Setpoint Adjust ▲ or ▼ arrow until the temperature limit you want appears in the setpoint display. The low limit must be set at a temperature less than or equal to the drying setpoint. The minimum setting is 100° F (38° C).

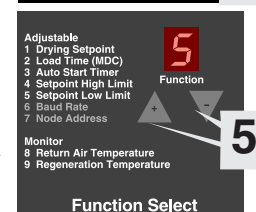
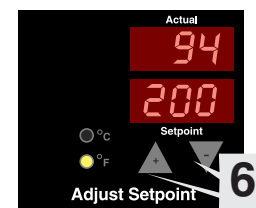

These high and low temperature limits will remain active until you change the settings.

NOTE: The factory default settings are 400° F (204° C) for the high limit and 100° F (38° C) for the low limit.

To START CONVEYING

- 1 Move the SC-MDC to the processing machine.**
Lock the wheels and connect the main power source.
Connect water source if you have the aftercooler.

- 2 Mount the K Loader on the feed throat.**
Push the K Loader onto the mounting bracket.

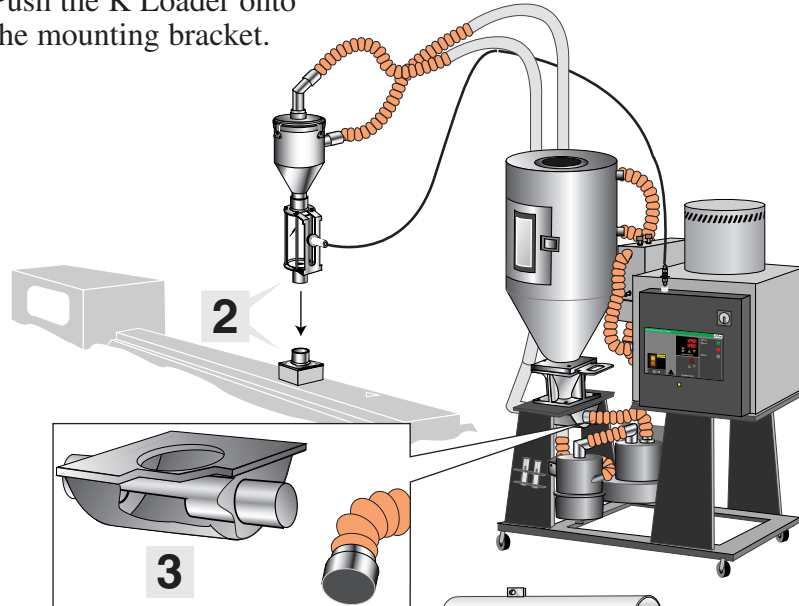

- 3 Place the appropriate material insert inside the distribution box.**

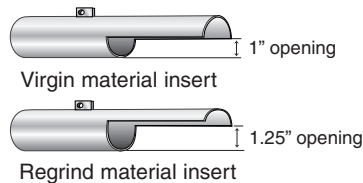

- 4 Make sure all hoses are connected securely.**

- 5 Adjust the demand sensor.**

Position the sensor at the lowest level of material that you want to maintain in the viewing chamber before another load cycle begins. Make sure the sensor rests against the sight glass.

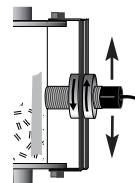

- 6 Set the load time.**

The default setting is 5 seconds. If you want a different load time, press the Function Display ▲ or ▼ arrow until 2 appears in the Function display. Press Setpoint Adjust ▲ or ▼ arrow until the desired load time appears in the setpoint display. Maximum = 15 seconds.

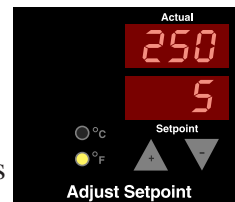

- 7 Press the  CONVEYING ON/OFF button.**

- ◆ The ON/OFF button lights
- ◆ The conveying blower starts, if the demand sensor doesn't see material.

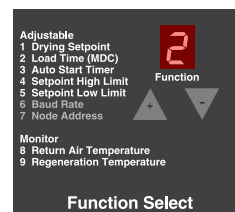

To STOP CONVEYING

- 1 Press the  CONVEYING ON/OFF button.**
 - ◆ The ON/OFF button light turns off.
 - ◆ The conveying blower stops.

If you plan to move the SC-MDC to another location:

- Disconnect the power and water sources.
- Remove the K Loader from the processing machine and secure to the SC-MDC cart for transport.

If you plan to change materials:

See *Cleaning the Hopper*, *Cleaning the Conveying Lines* and *Cleaning the K Loader* in the MAINTENANCE section

TRANSPORTING THE SC-MDC

The SC-MDC can be moved to another processing machine, to a pre-drying area or to an area away from the processing machine for cleaning and maintenance. To transport safely:

- 1 Disconnect the power and water sources.**
- 2 Place the K Loader on its transport bracket on the SC-MDC cart.** Tighten the thumbscrew to secure the k Loader to the bracket.
- 3 Unlock the wheels and move the SC-MDC** by pushing or pulling with the handles on the cart.

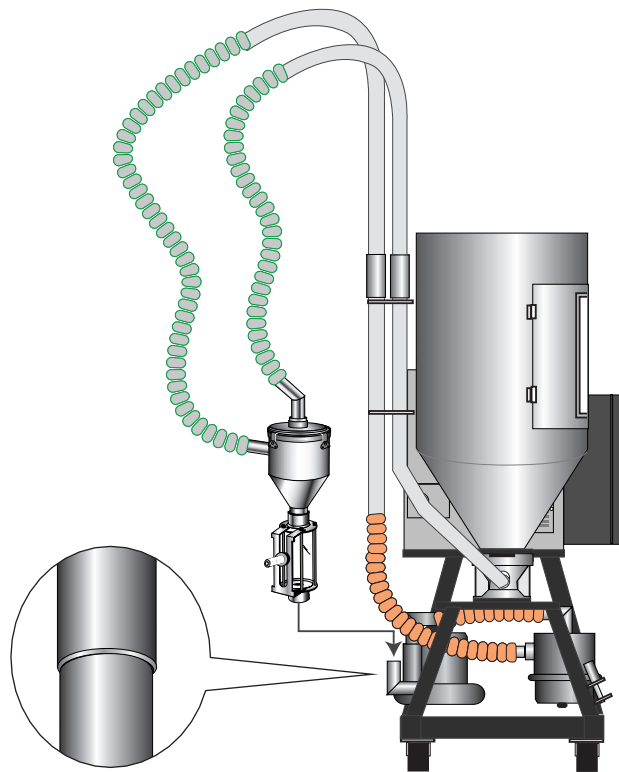

MAINTENANCE

- *Maintenance checklist* 5-2
- *Cleaning the hopper* 5-3
- *Cleaning the conveying lines* 5-4
- *Cleaning the K Loader* 5-4
- *Cleaning the dust collector* 5-5
- *Cleaning the process filter* 5-6
- *Cleaning the regeneration filter* ... 5-6
- *Cleaning the aftercooler coils* 5-6
- *Inspect hoses and gaskets* 5-7

PREVENTATIVE MAINTENANCE CHECKLIST

Routine maintenance will ensure optimum operation and performance of the SC Carousel Dryer. We recommend the following maintenance schedule and tasks.

● Whenever you change materials

- Drain and clean the drying hopper.
- Drain and clean the conveying hoses, K Loader and distribution box.

● Weekly, or as often as needed

- Clean the dust collector.**
You may need to empty the dust collector and clean its filter more often than weekly. Frequency depends on how much material you process and how dusty or full of fines it is.
- Clean the process and regeneration filters.**
You may need to clean filters more often than weekly. Frequency depends on how much material you process and how dusty or full of fines it is.
- Inspect hoses and hose connections.**
Check for damage, kinks or loose hose clamps. Replace any hoses that show signs of damage or wear. Reposition and tighten loose hose clamps.

● Monthly

- Clean the aftercooler coils.**
You may need to clean the coils more often than monthly. Frequency will depend on the type and volume of material you process.

● Every six months

- Inspect gaskets for damage or wear.**
Damaged gaskets can allow moisture to seep into the closed-loop drying system. Replace any gasket that is torn or cracked.



CAUTION: Hot surfaces.
Always protect yourself from hot surfaces inside and outside the dryer and drying hopper.

CLEANING THE HOPPER

The hopper, spreader cone and discharge assembly should be cleaned thoroughly between material changes to prevent resin contamination.

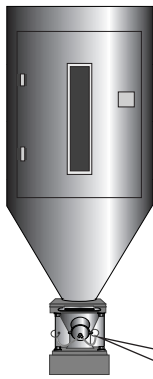

Place a container beneath the hopper's drain port to catch the material.

- 1 Open the hopper slide gate.**
- 2 Remove the drain-port plug.**
Pull the pin and allow the plug to drop. Drain, then vacuum remaining pellets.

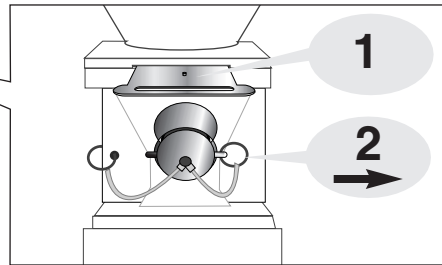

- 3 After draining material, open the hopper door.**

You must lift the safety catch below the sight glass on the hopper door before pulling the door handle open.



- 4 Remove the spreader cone.** Reach into the hopper. Grasp the spreader cone tube, lift up slightly, twist and then push down to release it. Tilt the cone assembly and pull it out through the hopper door.

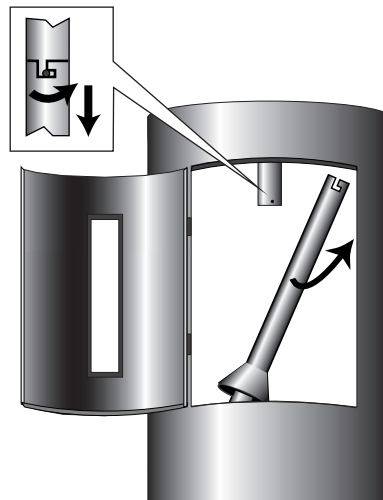

- 5 Clean the spreader cone and the inside of the hopper.** Make sure you also clean the return air screen at the return air outlet of the hopper.

- 6 Repeat the steps in reverse order** to reassemble the hopper before adding material.

CLEANING THE CONVEYING LINES

This method should be used only after most of the material has been drained from the drying hopper.

- 1 Disconnect the material line from the K Loader.**
- 2 Place the disconnected hose inside a container.**
- 3 Turn conveying on** by pressing the CONVEYING ON/OFF button.

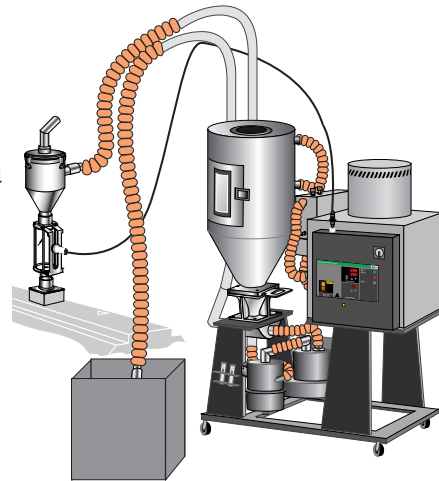

CLEANING THE K LOADER



CAUTION: Wear eye protection.

If you use compressed air to clean these components, wear safety glasses to protect yourself from airborne materials.

The K Loader should be cleaned anytime you change materials. Replace the screen mesh filter if it is torn, damaged, distorted or so clogged with material that it cannot be cleaned.

- 1 Turn off the conveying system, and disconnect the air and material hoses from the K Loader.**
- 2 Remove the K Loader lid.**
Release the twist clamps and lift the lid.
- 3 Remove and clean the mesh filter.**
Rotate the mesh filter against the loader lid so that it will release. Use vacuum or compressed air to clean the screen.
- 4 Remove and clean the loader body.**
Lift the loader body to release it from the viewing chamber. Clean inside the loader body with a clean rag.
- 5 Remove and clean the viewing chamber.**
Lift the viewing chamber to release it from the mounting bracket. Clean inside with a clean rag.
- 6 Reassemble the K Loader.** Make sure the viewing chamber and loader body seat snugly inside the O-ring couplings.

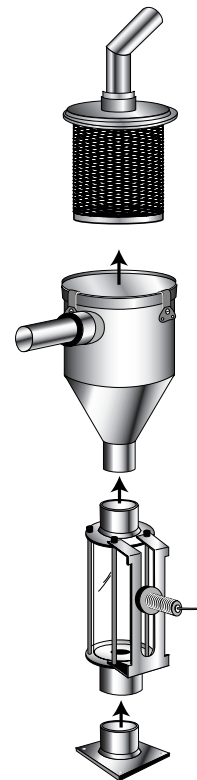

The dust collector filters dust and fines from the air used to convey material. The filter should be cleaned regularly to maintain conveying air flow and optimum performance of the conveying blower.

1 Turn off the conveying system.

Press the CONVEYING ON/OFF button on the dryer control panel.

2 Remove the dust collector lid.

Loosen the knob at the base of the lid.

3 Empty fines and dust that have collected in the lid.

4 Remove the conveying filter.

Loosen the retaining nut.

5 Inspect and clean the filter.

If the filter is torn or has holes in it, replace it. If you use compressed air to clean the filter, be sure to blow from the inside out.

6 Clean the inside of the dust collector housing.

You can use a vacuum, or wipe the inside with a clean rag.

7 Reassemble the dust collector.

Place the filter back in the housing, making sure the threaded rod extends through the center. Tighten the retaining nut on the rod. Put the lid back onto the housing and tighten the knob.

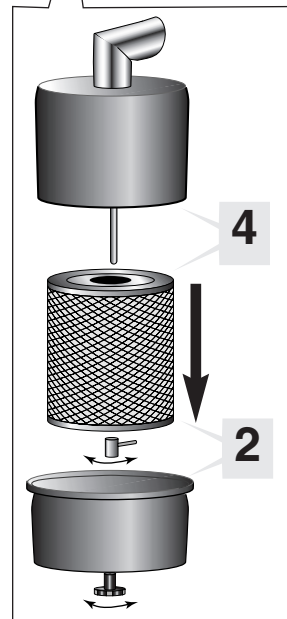
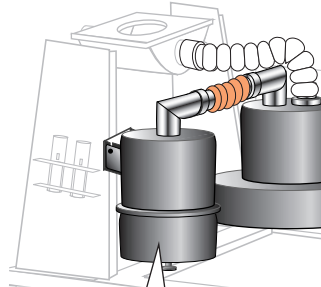

CLEANING THE DUST COLLECTOR



CAUTION:
Wear eye protection.

If you use compressed air to clean these components, wear safety glasses to protect yourself from air-borne materials.

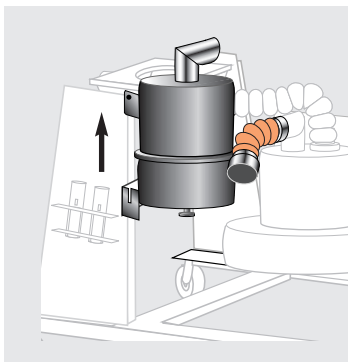

TIP: You can easily remove the dust collector so that it can be replaced with a spare clean one, or taken to a remote location for cleaning.

To remove:
Disconnect the hoses and lift the dust collector from its mounting bracket.

CLEANING THE PROCESS FILTER



Clogged filters reduce air flow and dryer efficiency. Cleaning frequency depends on how much material you process and how dusty it is.

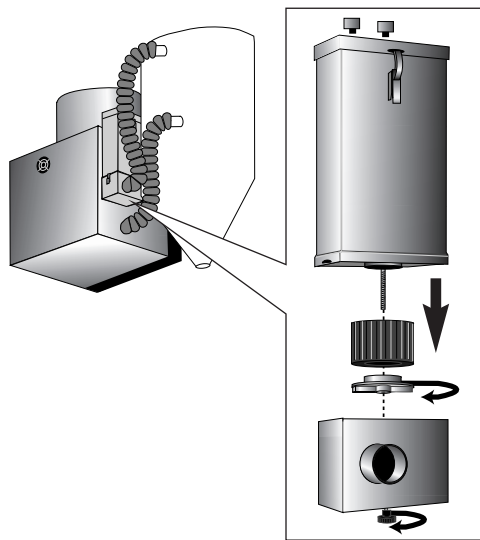

- 1 Loosen the knob** below the process filter box and remove the box.
- 2 Clean the filter box.**
- 3 Remove the filter** by turning the metal end cap. Clean the filter. If the filter is worn, damaged or clogged, replace it.
- 4 Reassemble** by repeating the steps in reverse order.

CLEANING THE REGENERATION FILTER

- 1 Remove the regeneration filter.**
- 2 Clean the filter.** Replace the filter if it is worn, damaged or hopelessly clogged with dirt, fines or dust.
- 3 Reassemble** by repeating the steps in reverse order.

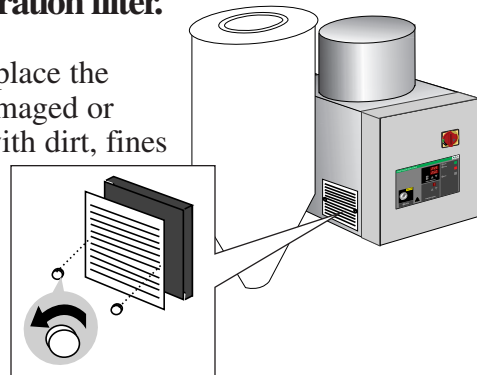

CLEANING THE AFTERCOOLER COILS

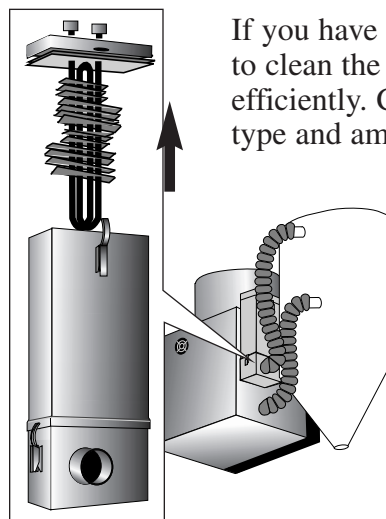

If you have the optional aftercooler, you need to clean the cooling coils to keep them working efficiently. Cleaning frequency depends on the type and amount of material you process.

- 1 Release the latches** at the top of the aftercooler.
- 2 Pull the coils out** of the aftercooler housing.
- 3 Clean the coils** with high-pressure steam, then reassemble.

Loose or damaged hoses, gaskets and O-ring seals can allow moisture to seep into the closed-loop drying system.

- 1 Tighten any loose hose clamps.**
- 2 Replace worn or damaged hoses and gaskets.**
- 3 Replace cracked, cut or damaged O-rings.**
Apply petroleum jelly around the inside of the O-ring couplings.

INSPECT HOSES AND GASKETS

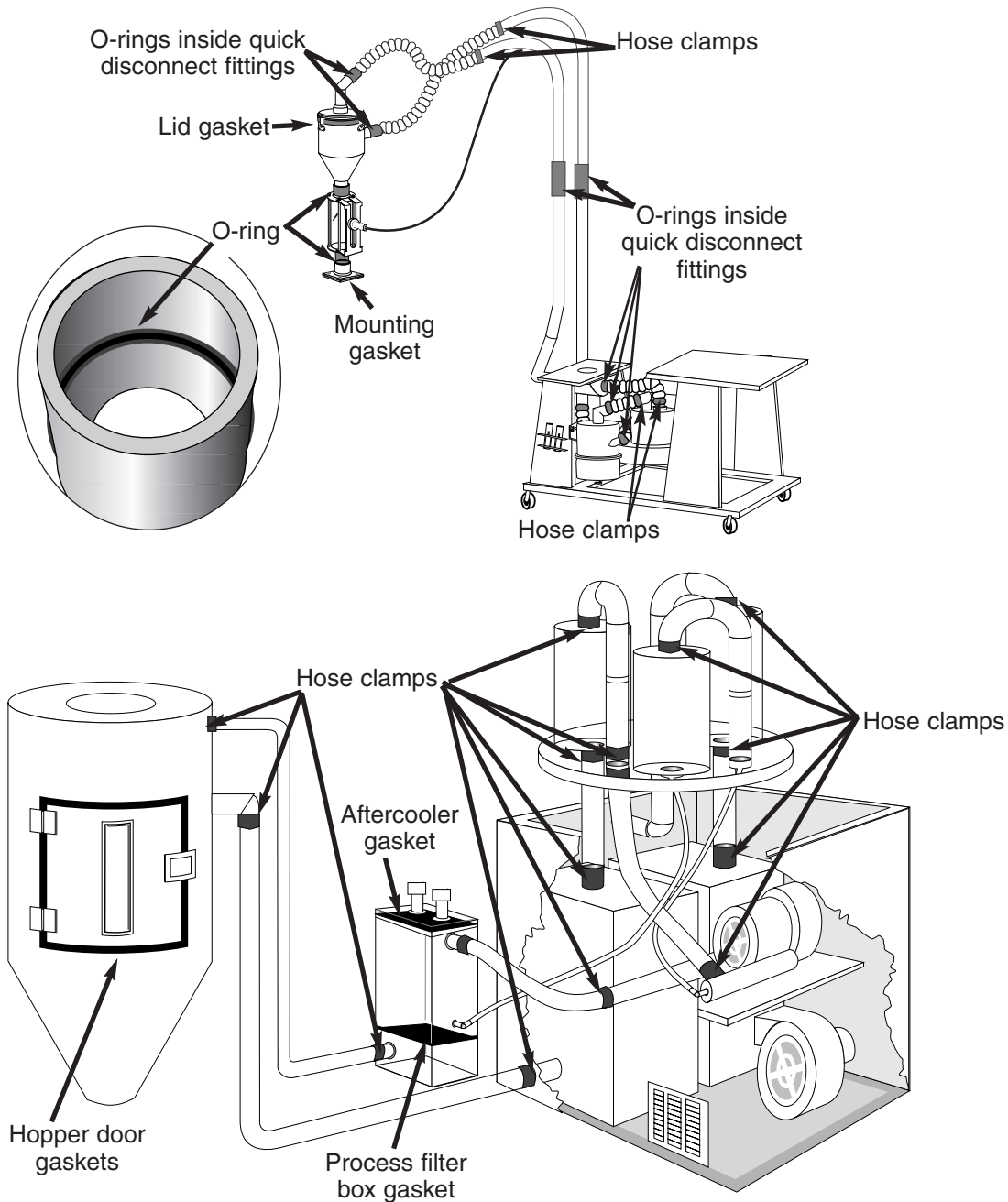

TROUBLESHOOTING

- *Before beginning* 6-2
- *A few words of caution* 6-2

DIAGNOSTICS

- *How to identify the cause of a problem* 6-3
- *Dryer will not power up* 6-4
- *Shut down alarms* 6-4
Err 01 through Err 08
- *Passive alarms* 6-9
Err 09 through Err 13

REPAIR

- *Checking motor overloads* 6-14
- *Replacing fuses* 6-15
- *Checking heater contactors* 6-15
- *Checking or replacing temperature sensors* 6-16
- *Adjusting the demand sensor* 6-17
- *Adjusting the limit switch* 6-18
- *Replacing heater elements* 6-19
- *Replacing desiccant tanks* 6-20
- *Refilling desiccant tanks* 6-21
- *Adding an aftercooler* 6-22

BEFORE BEGINNING

You can avoid most problems by following the recommended installation and maintenance procedures outlined in this User Guide. If you do have a problem, this section will help you determine what caused it and how to fix it.

Before you start pulling side panels off the dryer:

❑ Diagnose causes from the front of the dryer.

You can locate any problem from the front of the dryer.

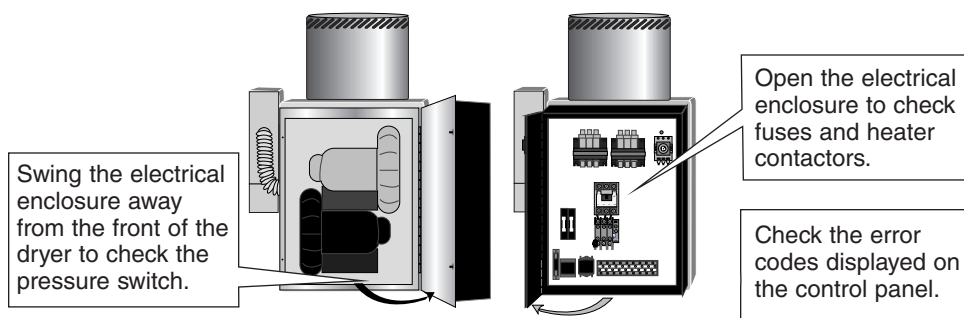

❑ Find the wiring and equipment diagrams that were shipped with your dryer.

These diagrams are the best reference for correcting a problem. The diagrams also will note any custom features, such as special wiring or alarm capabilities, not covered in this User Guide.

A FEW WORDS OF CAUTION

The SC Carousel Dryer is equipped with numerous safety devices. Do not remove or disable them. Improper corrective action can lead to hazardous conditions and should never be attempted to sustain production



WARNING: Only qualified service personnel should examine and correct problems that require opening the dryer's electrical enclosure or using electrical wires to diagnose the cause.



WARNING: High voltage.

Always stop the SC Carousel dryer, disconnect and lock out the main power source before troubleshooting or performing repairs.



CAUTION: Hot surfaces.

Always protect yourself from hot surfaces inside and outside of the dryer and hopper.

Most dryer malfunctions are indicated by an illuminated alarm light and error codes displayed on the SC dryer control panel.

HOW TO IDENTIFY THE CAUSE OF A PROBLEM

A problem can trigger two types of alarms:

- **Shut Down:** The dryer has automatically shut down because it detected a serious problem that could damage your material or dryer.
- **Passive:** The dryer continues to operate, but warns of a problem that could prevent correct drying of your material. If ignored, this problem could lead to a condition that will shut down the dryer.

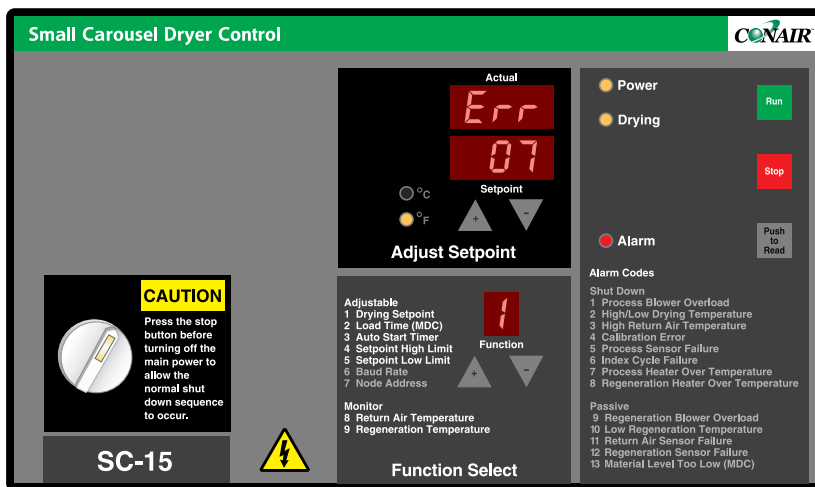

When an alarm light is displayed:

- 1** Press  to display the alarm message and silence the optional audible alarm.
- 2** Find the error code in the diagnostics table of this troubleshooting section.

NOTE: When the dryer detects abnormally high temperature in the process heater, the dryer immediately shuts down and Err 7 flashes in the display windows. The alarm light does not illuminate.

DRYER WILL NOT POWER UP

You have a problem with the main power circuit or the dryer's microprocessor board, if the dryer control panel does not light when the Power ON/OFF switch is turned to the ON position.

Symptom	Possible cause	Solution
Turning the Power ON/OFF switch does not turn on the dryer control.	Is the main power supply to the dryer on?	Verify that the main power supply is on and that the dryer's main power disconnect dial is in the ON position.
	Has the dryer blown a fuse?	Disconnect power. Open the dryer's electrical enclosure and check the main power fuses. <i>See REPLACING FUSES.</i>
	Is the microprocessor board in the dryer damaged?	Contact Conair service.

SHUT DOWN ALARMS

When a shut down alarm lights, the dryer has detected a problem or combination of problems that could damage your dryer or materials. When a shut down alarm occurs:

- ◆ The dryer automatically shuts off.
- ◆ The alarm light turns on.
- ◆ The power light remains on.
- ◆ Pressing the Push To Read button displays an error code.

Alarm	Possible cause	Solution
 <p>The process blower overload has tripped. The blower is drawing excessive current.</p> <p>WARNING: Only qualified electrical service personnel should examine and correct problems that require opening the dryer's electrical enclosure or checking electrical current to diagnose the cause of a problem.</p>	Is the correct voltage supplied to the dryer?	Check the process blower current against the voltage and amp rating on the motor nameplate. If currents do not match, make sure the transformer is wired correctly.
	Is the blower overload set correctly? (SC-MDC 30 and 60 only)	Disconnect power and open the electrical enclosure. Adjust the blower overload setting, if necessary. Press the overload reset button to resume operation. <i>See CHECKING MOTOR OVERLOADS.</i>
	Is the blower damaged?	Replace the blower, if supply voltage, transformer wiring and overload settings are correct, but the blower continues to draw excessive current.

When a shut down alarm lights, the dryer has detected a problem or combination of problems that could damage your dryer or materials. When a shut down alarm occurs:

- ◆ The dryer automatically shuts off.
- ◆ The alarm light turns on.
- ◆ The power light remains on.
- ◆ Pressing the Push To Read button displays an error code.

SHUT DOWN ALARMS

Alarm	Possible cause	Solution
<div data-bbox="245 558 418 737" data-label="Image"> </div> <p data-bbox="240 751 526 1031">The RTD probe at the drying hopper inlet sensed that the actual drying temperature is more than 20° F (7° C) higher or lower than the setpoint.</p> <div data-bbox="256 1209 310 1262" data-label="Image"> </div> <p data-bbox="321 1230 488 1262">WARNING:</p> <p data-bbox="240 1266 526 1556">Only qualified electrical service personnel should examine and correct problems that require opening the dryer's electrical enclosure or checking electrical current to diagnose the cause of a problem.</p>	<p data-bbox="553 569 837 632">Are process air lines restricted?</p>	<p data-bbox="938 569 1346 705">Check the delivery air hose and process filter. Remove block age. Straighten crimps in hoses. Attach any loose hoses.</p>
	<p data-bbox="553 737 894 873">Is the dryer too far from the hopper to maintain setpoint temperature of the drying air?</p>	<p data-bbox="938 737 1346 905">The dryer should be no more than 5 feet (1.5 m) from the hopper. Move the dryer closer to the hopper, or insulate the air delivery hoses.</p>
	<p data-bbox="553 936 906 999">Is the RTD temperature probe installed correctly?</p>	<p data-bbox="938 936 1346 1178">Verify that the tip of the RTD probe is inserted into the center of the delivery air inlet of the hopper. Temperature readings will be incorrect, if the sensor touches the walls of the inlet pipe.</p>
	<p data-bbox="553 1209 854 1314">Is the process blower rotating in the wrong direction? (SC-MDC 30 and 60 only)</p>	<p data-bbox="938 1209 1346 1356">If the process blower is turning opposite the arrow stamped on its housing, reverse any two leads connecting main power to the dryer.</p>
	<p data-bbox="553 1388 837 1451">Did a process heater element fail?</p>	<p data-bbox="938 1388 1346 1629">Using an amp meter, check the current in the heater element wires. If the current is lower than indicated on the wiring diagrams, replace the heater element. <i>See REPLACING HEATER ELEMENTS.</i></p>
<p data-bbox="553 1661 837 1724">Did a process heater contactor fail?</p>	<p data-bbox="938 1661 1346 1860">Disconnect power. Check the continuity of the contactor outputs. If the ohm reading is zero or near zero, replace the contactor. <i>See CHECKING HEATER CONTACTORS.</i></p>	

SHUT DOWN ALARMS

When a shut down alarm lights, the dryer has detected a problem or combination of problems that could damage your dryer or materials. When a shut down alarm occurs:



- ◆ The dryer automatically shuts off.
- ◆ The alarm light turns on.
- ◆ The power light remains on.
- ◆ Pressing the Push To Read button displays an error code.

Alarm	Possible cause	Solution
 <p>Dew point will suffer because the air returning from the hopper is too hot for the desiccant to work at capacity. The return air sensor has been set to alarm at temperatures over 180° F (64°C).</p>	<p>Does the drying hopper contain enough material?</p>	<p>Verify that your material supply system is working. Refer to the manuals for your conveying system, if necessary.</p>
<p>Are you drying with high heat or low throughputs?</p>	<p>You may need an aftercooler if you are drying at temperatures over 250° F (121°C), or if you are drying small amounts of material. An amount less than 50% of the dryer’s rated capacity is considered small. <i>See ADDING AN AFTERCOOLER.</i> If you have an aftercooler, go to the next step.</p>	
<p>Is water flowing to your aftercooler?</p>	<p>Turn on the water supply, or fix the problem that prevents water from flowing through the aftercooler. The water flow must equal at least 3 gallons (11.36 liters) per minute at up to 90° F (32° C).</p>	
<p>Are the aftercooler coils dirty?</p>	<p>Clean the aftercooler coils. <i>See MAINTENANCE: CLEANING THE AFTERCOOLER COILS.</i></p>	

SHUT DOWN ALARMS

When a shut down alarm lights, the dryer has detected a problem or combination of problems that could damage your dryer or materials. When a shut down alarm occurs:



- ◆ The dryer automatically shuts off.
- ◆ The alarm light turns on.
- ◆ The power light remains on.
- ◆ Pressing the Push To Read button displays an error code.

Alarm	Possible cause	Solution
 <p>The dryer did not calibrate temperature correctly.</p>	<p>Electrical interference or a controller problem prevented correct calibration of temperature.</p>	<p>Turn the power off and back on. Press RUN to resume normal operation. Contact Conair service if you cannot clear the error message by cycling power off and on, or if the calibration error continues to occur.</p>
 <p>The RTD temperature sensor at the drying hopper inlet has failed.</p>	<p>Is the RTD probe (drying temperature sensor) connected correctly?</p> <p>Is the RTD probe damaged?</p>	<p>Verify that the RTD probe is plugged into the receptacle on the electrical enclosure and that the cable is not damaged.</p> <p>If the connections are correct, the probe or cable is probably damaged. Check for obvious signs of damage, and replace if necessary.</p>
 <p>The dryer shut down because the desiccant tank carousel did not rotate from one position to the next within the correct time.</p>	<p>Is the limit switch adjusted correctly?</p> <p>Is the bed-drive motor damaged?</p> <p>Is there contamination between the bed plates?</p>	<p>Adjust the limit switch so that it drops into the valley along the edge of the bed plate. See Adjusting the Limit Switch.</p> <p>Check the voltage and electrical connections to the bed-drive motor. If you find 110 V and secure connections, the motor is damaged. Replace the motor.</p> <p>Remove the upper bed plate. Spray the surfaces with a non-oil based cleaning liquid and wipe with a soft cleaning rag. Reassemble the bed plates.</p>

SHUT DOWN ALARMS

When a shut down alarm lights, the dryer has detected a problem or combination of problems that could damage your dryer or materials. When a shut down alarm occurs:

- ◆ The dryer automatically shuts off.
- ◆ The alarm light turns on.
- ◆ The power light remains on.
- ◆ Pressing the Push To Read button displays an error code.

Alarm	Possible cause	Solution
 <p>The dryer detected excessive heat in the process heater box, or the high temperature sensor failed.</p> <p>NOTE: When this alarm occurs, the alarm light does not illuminate. Instead, Err 07 flashes in the display windows.</p>	<p>Was there a loss of power or improper shut down using the Power ON/OFF switch or the main power disconnect?</p> <p>Was there an electrical short in a heater contactor?</p> <p>Is the high temperature sensor adjusted correctly?</p>	<p>Turn power to the dryer off and then on. Allow the dryer to cool, then press RUN to restart. The power interruption prevented the heaters from cooling down after normal operation. This may have triggered a high-temperature alarm.</p> <p>Disconnect power. Check continuity of the process heater contactor output. <i>See CHECKING HEATER CONTACTORS.</i></p> <p>The high temperature should be set at 200° F (93° C)</p>
 <p>The dryer detected excessive heat in the regeneration heater box.</p>	<p>Did the microprocessor board fail?</p> <p>Was there a loss of power or improper shut down using the Power ON/OFF switch or the main power disconnect?</p> <p>Was there an electrical short in a heater contactor?</p> <p>Did the microprocessor board fail?</p>	<p>Contact Conair service.</p> <p>Turn power to the dryer off and then on. Allow the dryer to cool, then press RUN to restart. The power interruption prevented the heaters from cooling down after normal operation. This may have triggered a high-temperature alarm.</p> <p>Disconnect power. Check continuity of the process heater contactor output. <i>See CHECKING HEATER CONTACTORS.</i></p> <p>Contact Conair service.</p>

PASSIVE ALARMS

When a passive alarm lights, the dryer has detected a problem that could prevent correct drying of your material. When a passive alarm occurs:



- ◆ The alarm light turns on.
- ◆ The dryer continues to operate.
- ◆ Pressing the Push To Read button displays an error code.

Alarm	Possible cause	Solution
<div data-bbox="256 537 428 716" data-label="Image"> </div> <p data-bbox="250 758 521 926">The regeneration blower overload has tripped. The blower is drawing excessive current.</p> <div data-bbox="263 1016 529 1339" data-label="Text"> <p>WARNING: Only qualified electrical service personnel should examine and correct problems that require opening the dryer's electrical enclosure or checking electrical current to diagnose the cause of a problem.</p> </div>	<p data-bbox="553 541 914 611">Is the correct voltage supplied to the dryer?</p>	<p data-bbox="946 541 1338 852">Check voltage to and from the transformer. Main power supply voltage should match the rating on the dryer name plate. Voltage from the transformer to the blower should be 110V. If voltage is incorrect, make sure the transformer is wired correctly.</p>
<p data-bbox="553 888 862 957">Is the blower overload tripped?</p>	<p data-bbox="946 888 1328 1058">Disconnect power and open the electrical enclosure. Press the overload reset button to resume operation. <i>See CHECKING MOTOR OVERLOADS.</i></p>	
<p data-bbox="553 1098 894 1167">Did the pressure switch fail in the open position?</p>	<p data-bbox="946 1098 1346 1230">Using an ohmmeter, test the continuity of the switch when you start the dryer. If the switch does not close, replace it.</p>	
<p data-bbox="553 1266 883 1299">Is the blower damaged?</p>	<p data-bbox="946 1266 1328 1436">Replace the blower, if supply voltage, transformer wiring and overload settings are correct, but the blower continues to draw excessive current.</p>	

PASSIVE ALARMS

When a passive alarm lights, the dryer has detected a problem that could prevent correct drying of your material. When a passive alarm occurs:



- ◆ The alarm light turns on.
- ◆ The dryer continues to operate.
- ◆ Pressing the Push To Read button displays an error code.

Alarm	Possible cause	Solution
 <p>The regeneration temperature is too low.</p> <p> WARNING: Only qualified electrical service personnel should examine and correct problems that require opening the dryer's electrical enclosure or checking electrical current to diagnose the cause of a problem.</p>	<p>Is the regeneration filter clogged?</p>	<p>Clean the regeneration filter.</p>
	<p>Are there any leaks in the regeneration air circuit?</p>	<p>Check hoses, gaskets and O-rings. Replace any that are cracked or excessively worn. make sure hose clamps are secure.</p>
	<p>Is the regeneration temperature sensor installed correctly?</p>	<p>Verify that the temperature sensor is positioned properly at the outlet of the regeneration heater box.</p>
	<p>Was there an electrical short in a heater contactor?</p>	<p>Disconnect power. Check continuity of the regeneration heater contactor outputs. <i>See CHECKING HEATER CONTACTORS.</i></p>
	<p>Did a regeneration heater element fail?</p>	<p>Check the regeneration heater elements. Only qualified electrical service personnel should check amperage and voltages of heater wires at the front of the dryer. <i>See REPLACING HEATER ELEMENTS.</i></p>
	<p>Did the regeneration blower fail?</p>	<p>Compare motor current to the amp rating on the motor nameplate. If currents, do not match and the transformer is wired correctly, replace the blower.</p>
	<p>Is the desiccant contaminated?</p>	<p>If air and electrical circuits work correctly, the problem probably is contaminated desiccant. <i>See REPLACING DESICCANT TANKS.</i></p>

PASSIVE ALARMS

When a passive alarm lights, the dryer has detected a problem that could prevent correct drying of your material. When a passive alarm occurs:

- ◆ The alarm light turns on.
- ◆ The dryer continues to operate.
- ◆ Pressing the Push To Read button displays an error code.

Alarm	Possible cause	Solution
 <p>The return air temperature sensor has failed.</p>	<p>Is the return air temperature sensor connected correctly?</p> <p>Is the return air temperature sensor damaged?</p>	<p>Verify that the return air temperature sensor wire is connected to the dryer's micro-processor board. Refer to the wiring diagrams that came with your dryer.</p> <p>Check the sensor for damage, and replace if necessary.</p>
 <p>The regeneration temperature sensor has failed.</p>	<p>Is the regeneration temperature sensor connected correctly?</p> <p>Is the regeneration temperature sensor damaged?</p>	<p>Verify that the regeneration temperature sensor wire is connected to the dryer's micro-processor board. Refer to the wiring diagrams that came with your dryer.</p> <p>Check the sensor for damage, and replace if necessary.</p>

PASSIVE ALARMS

When a passive alarm lights, the dryer has detected a problem that could prevent correct drying of your material. When a passive alarm occurs:

- ◆ The alarm light turns on.
- ◆ The dryer continues to operate.
- ◆ Pressing the Push To Read button displays an error code.

Symptom	Possible cause	Solution
<div data-bbox="282 506 456 684" data-label="Image"> </div> <p data-bbox="277 695 521 793">The material level inside the vacuum receiver is too low.</p>	<p data-bbox="581 520 906 583">Is material flowing into the distribution box?</p> <p data-bbox="581 615 927 709">Is air flow through the conveying lines restricted or blocked?</p> <p data-bbox="581 961 927 1056">Are the conveying hoses connected correctly, or is there an air leak?</p> <p data-bbox="581 1381 927 1476">Are you using the correct material insert in the distribution box?</p> <p data-bbox="581 1665 906 1759">Is the conveying blower rotating in the wrong direction?</p>	<p data-bbox="971 520 1370 583">Make sure the slide gate on the drying hopper is open.</p> <p data-bbox="971 615 1370 940"> <input type="checkbox"/> Clean the conveying filter. Replace the filter, if it is torn or hopelessly clogged. <input type="checkbox"/> Clean the K Loader filter basket. Replace the filter, if it is damaged. <input type="checkbox"/> Check the conveying hoses for restrictions or blockage. Remove blockages and straighten crimped hoses. </p> <p data-bbox="971 972 1370 1350"> <input type="checkbox"/> Verify that conveying hoses are connected to the correct inlets and outlets. <input type="checkbox"/> Check conveying hoses, hose connections and O-rings in quick disconnect mechanisms. Secure loose hose clamps. Make sure quick disconnect hoses and K Loader are seated correctly. Replace any damaged hoses, O-rings or gaskets. </p> <p data-bbox="971 1381 1370 1633">If you are conveying regrind, use the material insert with the larger opening. If you are conveying virgin material, use the insert with the smaller opening. Verify that the insert has been positioned correctly in the distribution box.</p> <p data-bbox="971 1665 1370 1854">Check the blower rotation. If it is rotating in the opposite direction of the arrow stamped on the blower, reverse any two leads at the conveying motor starter.</p>

PASSIVE ALARMS

When a passive alarm lights, the dryer has detected a problem that could prevent correct drying of your material. When a passive alarm occurs:

- ◆ The alarm light turns on.
- ◆ The dryer continues to operate.
- ◆ Pressing the Push To Read button displays an error code.

Symptom	Possible cause	Solution
<div data-bbox="251 504 422 682" data-label="Image"> </div> <p data-bbox="238 693 487 787">The material level inside the vacuum receiver is too low.</p>	<p data-bbox="544 514 901 577">Did the conveying blower overload trip?</p> <p data-bbox="544 1018 844 1081">Is the demand sensor adjusted correctly?</p> <p data-bbox="544 1438 844 1501">Is the demand sensor faulty?</p>	<ul style="list-style-type: none"> <li data-bbox="933 514 1339 735"> <input type="checkbox"/> Disconnect power and open the electrical enclosure. Adjust the blower overload setting, if necessary. Press the overload reset button to resume operation. <i>See CHECKING MOTOR OVERLOADS.</i> <li data-bbox="933 745 1339 997"> <input type="checkbox"/> Check the blower current against the voltage and amp rating on the nameplate. If the motor is drawing excessive current, and everything is wired correctly, you may need to replace the blower. Call Conair service. <li data-bbox="933 1029 1339 1218"> <input type="checkbox"/> Make sure the demand sensor rests against the glass, and is positioned at the minimum level of material you want to maintain in the viewing chamber. <li data-bbox="933 1228 1339 1417"> <input type="checkbox"/> Adjust the sensitivity of the capacitive demand sensor. If it is too sensitive, the sensor will not allow the loader to fill. <i>See ADJUSTING THE DEMAND SENSOR.</i> <p data-bbox="933 1449 1339 1732">Make sure the cable and wiring from the demand sensor to the dryer control are connected correctly. If the wiring and sensor adjustments are correct, but the sensor still does not work, call Conair service. You may need to replace the sensor.</p>

CHECKING MOTOR OVERLOADS



IMPORTANT:

Always refer to the wiring diagrams that came with your dryer to locate specific electrical components. Illustrations in the User Guide are intended to be representative only.

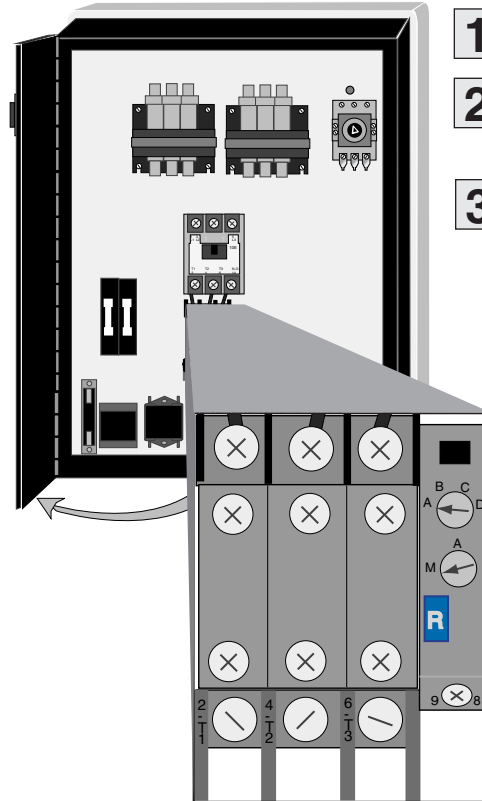

1 Disconnect power.

2 Open the electrical enclosure door.

3 Check the overload.

If the blue reset button is out, the overload has tripped. Press the button to reset the overload and resume normal operation.

If the overload continues to trip, check the overload settings. The factory setting for the overload is the blower's amp rating plus 0.1 amp.

IMPORTANT: Always refer to the wiring diagrams that came with your dryer to locate specific electrical components. Illustrations in the User Guide are intended to be representative only.

- 1** Disconnect power.
- 2** Open the electrical enclosure door.
- 3** Check the fuse.
If necessary, pull the fuse out and replace it with a fuse of the same type and rating.

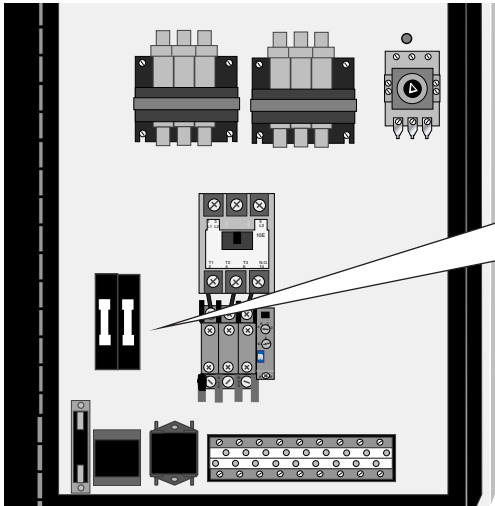

Fuse Block

To locate the appropriate fuse and replacement part, refer to the wiring diagrams that came with your dryer.

REPLACING FUSES



IMPORTANT:
Always refer to the wiring diagrams that came with your dryer to locate specific electrical components. Illustrations in the User Guide are intended to be representative only.

- 1** Disconnect power.
- 2** Open the electrical enclosure.
- 3** Locate the process or regeneration contactors.
Refer to the wiring diagrams that came with your dryer.
- 4** Check continuity using an ohmmeter.

Process heater contactors

If ohms at coil equal zero, replace the contactor.

Regeneration heater contactors

If ohms at coil equal zero, replace the contactor.

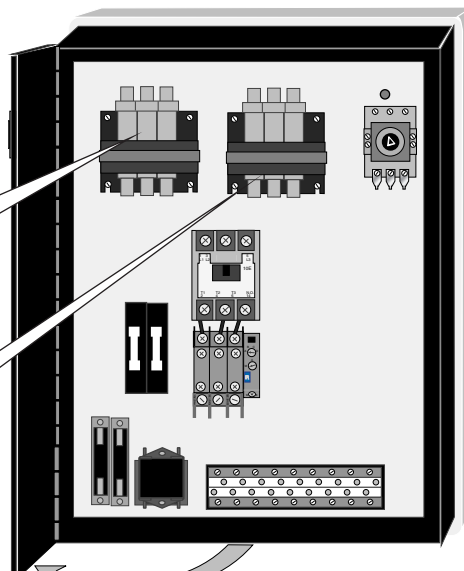

CHECKING HEATER CONTACTORS



IMPORTANT:
Always refer to the wiring diagrams that came with your dryer to locate specific electrical components. Illustrations in the User Guide are intended to be representative only.

CHECKING OR REPLACING TEMPERATURE SENSORS



IMPORTANT:
Always refer to the wiring diagrams that came with your dryer to locate specific electrical components. Illustrations in the User Guide are intended to be representative only.

The SC dryer uses RTD sensors to monitor the temperatures of the drying air, the return air, the regeneration exhaust and the regeneration and process heater boxes.

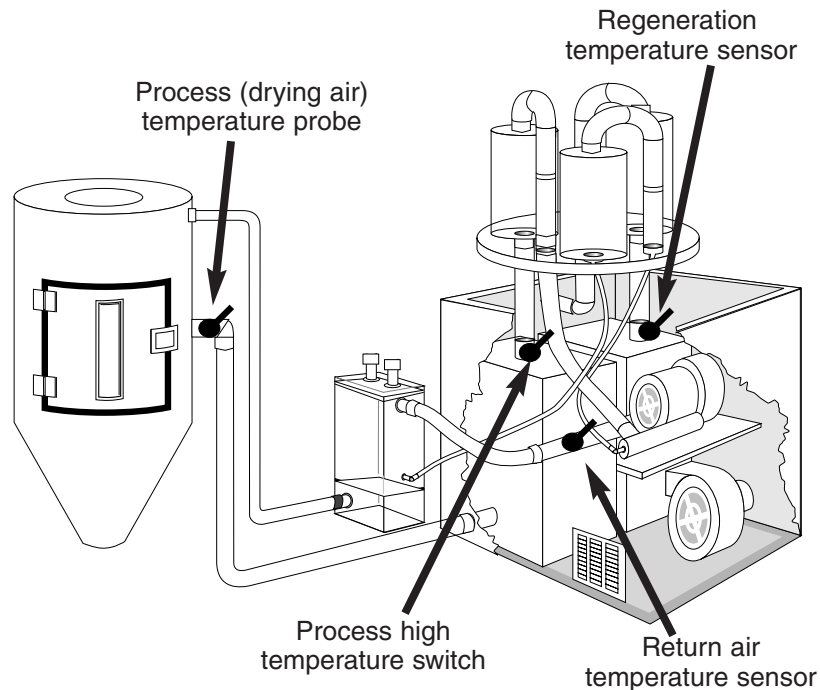
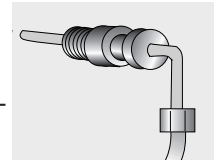

To check or replace an RTD sensor:

- 1 Disconnect and lockout the main power supply.**
- 2 Remove dryer panels, as necessary.**
- 3 Locate the temperature sensor.**
- 4 Check the sensor position and condition.**
Temperature readings will be incorrect, if the sensor is touching the wall of an air hose or pipe or if the sensor or wiring is damaged. The tip of the sensor should be centered within the air hose or pipe. Sensor wires should be attached to the appropriate connection points on the dryer's electrical enclosure or microprocessor board.
- 5 Replace the sensor, if necessary.**

ADJUSTING THE DEMAND SENSOR

The capacitive demand sensor usually does not need adjustment. But you may need to readjust the demand sensor when you change materials, or if you regularly load dusty materials.

The LED light on the sensor should be OFF when material is present in the viewing chamber at the level of the sensor.

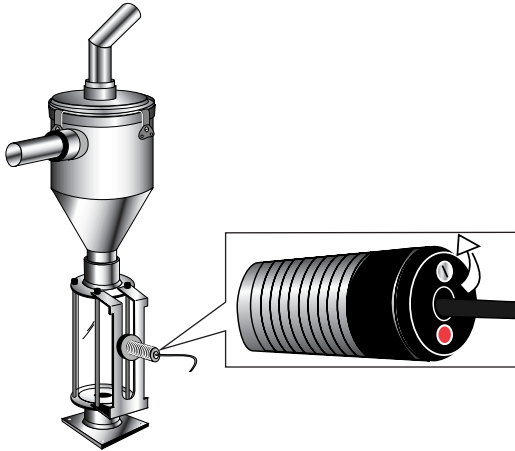

- 1** Make sure power is on to the conveying control.
- 2** Make sure there is no material in the viewing chamber, and that the sensor is resting against the glass.
- 3** Remove the tape covering the sensor adjustment screw.
- 4** Turn the screw counterclockwise until the LED light comes on.
- 5** Turn the screw counterclockwise an additional quarter turn.

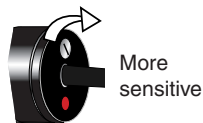

ADJUSTING THE LIMIT SWITCH



1 Stop the dryer.
Disconnect and lockout the main power.

2 Remove the carousel cover.

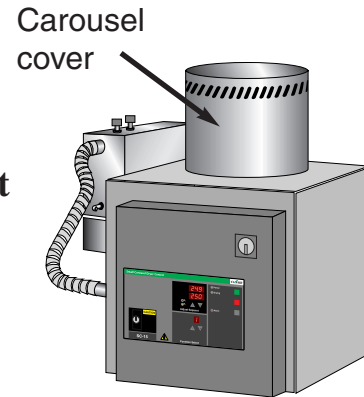

3 Loosen the screw on the limit switch bracket.

4 Slide the bracket left or right to position the limit switch so that its small roller drops into the valley on the bed plate. The roller should not hit the stationary bottom plate.

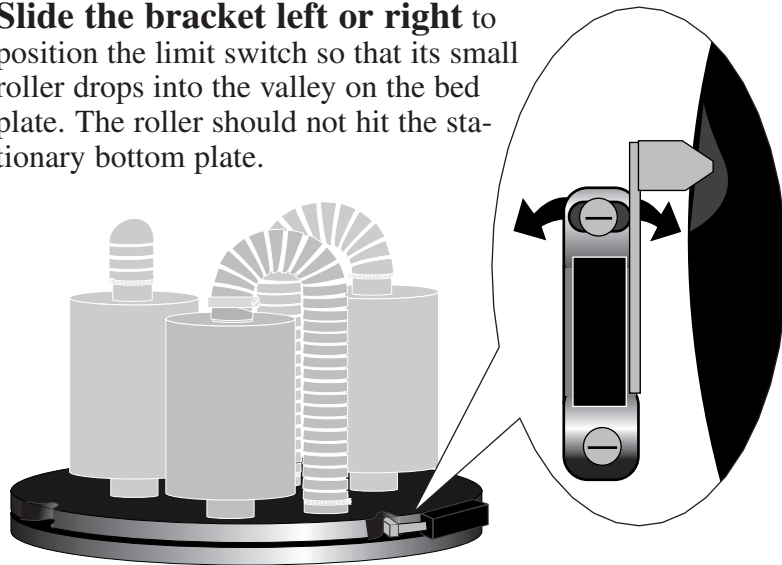

5 Test for correct indexing of the carousel.
Restore main power to the dryer. Hold the limit switch out of the valley on the carousel bed plate while you flip the toggle switch to START. Once the bed plate starts turning, release the switch.

If everything is adjusted correctly:

- ◆ The carousel bed turns.
- ◆ When the limit switch reaches the next valley in the bed plate, the carousel should stop turning.

6 Reset the desiccant carousel.
Continue indexing until the desiccant tanks return to the positions they were in when the dryer shut down.

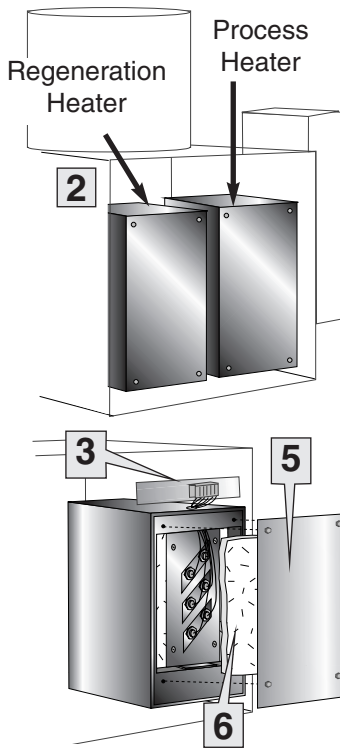

1 Disconnect power and remove the dryer's back panel.

2 Locate the appropriate heater box.

3 Detach the heater element wires from the terminal strip above the heater box. Each element has two wires.

4 Check continuity of the heater element wires. Replace any element that shows an ohm reading of zero or infinity.

5 Remove the heater cover.

6 Remove the insulation. Set the insulation aside for reassembly.

7 Remove the heater element assembly. Loosen the screws and pull the assembly out of the box.

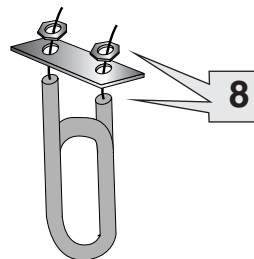
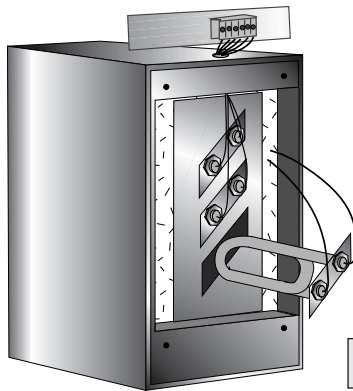

8 Replace the faulty heater element(s). Remove the nut holding the element to the assembly plate. Pull the element out of the plate. Insert the wires of a new element through the plate. Secure the element with the nut.

9 Reassemble. Follow steps in reverse order

REPLACING HEATER ELEMENTS



TIP: For faster repairs, keep a spare heater assembly that can be swapped for the assembly containing a faulty element.

Number of heating elements

	Process	Regeneration
SC7.5	2 (450w)	2 (450w)
SC15	3 (450w)	3 (450w)
SC30	6 (450w)	3 (450w)
SC60	6 (900w)	3 (900w)

REPLACING DESICCANT TANKS



The SC Carousel Dryer has disposal desiccant tanks. The tanks have been sealed, and should require no contact with the desiccant. **When desiccant becomes clogged or contaminated, you should replace all three tanks to ensure optimum performance.**

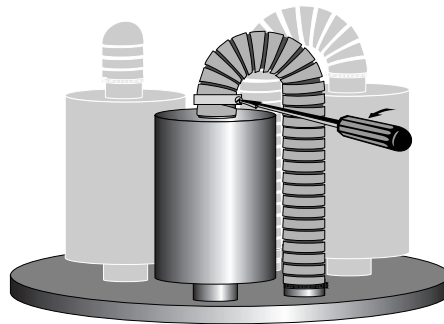

1 Stop the dryer and disconnect power.

2 Remove the carousel cover.

3 Disconnect the hose from the desiccant tank.

Loosen the hose clamp with a screw driver.

4 Lift the tank off the carousel assembly.

5 Discard the contaminated tank.

6 Check the O-rings in the carousel coupling. Replace any O-rings that are cracked, worn or damaged. Apply petroleum jelly on the inside of the coupling around the O-ring.

7 Place a new tank on the carousel assembly. Make sure the inlet/outlet tube of the tank seats fully into the O-rings on the carousel pipe.

8 Connect the hose to the top of the tank. Secure with the hose clamp.

9 Replace the carousel cover.

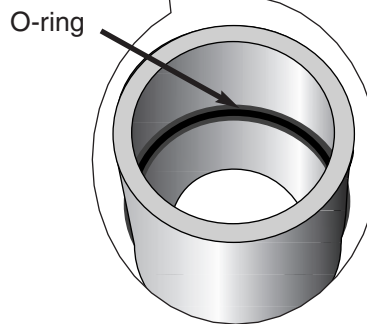
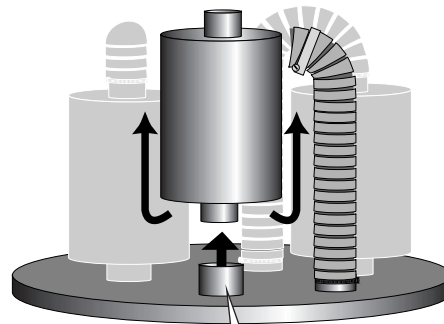

TIP: It's important that the new tanks are connected to the correct hoses. Mark the hoses as they are disconnected, or replace one tank at a time, to ensure that you install the new tanks in the correct positions.

When desiccant becomes clogged or contaminated, you should replace the desiccant in all three tanks to ensure optimum performance.

REFILLING THE DESICCANT TANK

- 1 Remove the desiccant tank from the carousel.**
See [REPLACING DESICCANT TANKS](#).
- 2 Remove the screws on the tank end plate.**
- 3 Remove the screen cap.**
Remove the two 1/4-20 nuts from the center post and pull the screen cap out.

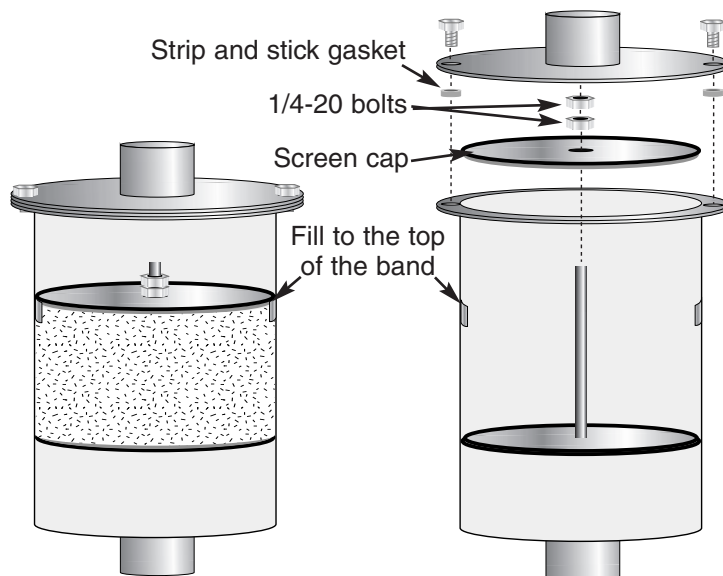

- 4 Remove the old desiccant.**
- 5 Replace the gasket on the flange, if necessary.**
- 6 Fill the tank with fresh desiccant.**
Fill the tank to the top of the band. Vibrate the tank for 15 minutes, then add more desiccant until the desiccant is level with the top of the band.
- 7 Reinstall the screen cap.**
Place the cap on the band. Install one of the 1/4-20 nuts on the center post and tighten. Do not over-tighten. Install the second 1/4-20 nut and tighten.
- 8 Reinstall the tank end plate.**
Place the end plat on the tank and tighten the screws.
- 9 Reinstall the desiccant tank on the carousel.**
See [REPLACING DESICCANT TANKS](#).

IMPORTANT: After filling with fresh desiccant, vibrate the tank for at least 15 minutes. Add desiccant as needed until level with the top of the band.

ADDING AN AFTERCOOLER

You can add an aftercooler to the SC Carousel Dryer by ordering the optional aftercooler coils. Installation is easy.

The optional aftercooler requires a source of city, tower or chiller water and a discharge or return line. You can use water at temperatures of 70 to 90° F (21° to 32° C). But the water flow should be at least 3 gallons (11.36 liters) per minute.

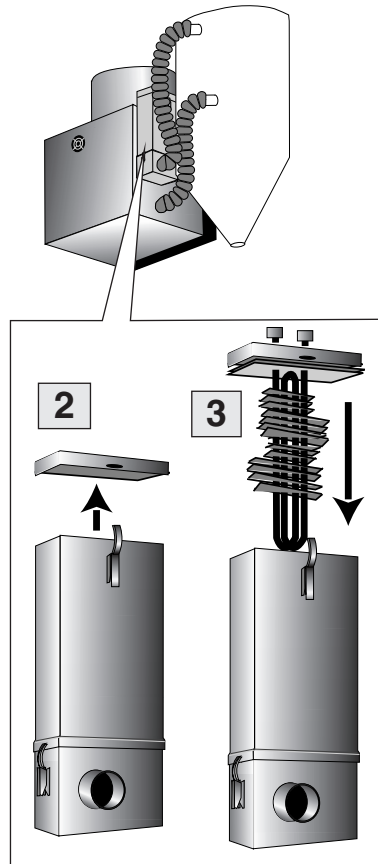

1 Stop the dryer and disconnect power.

2 Remove the aftercooler housing cover.

3 Insert the aftercooler coils into the housing. Make sure the latches on the housing are aligned with the latch holes in the aftercooler coil lid.

4 Secure the latches.

5 Connect the cooler inlet to the water source. If a manual shut off valve is used, it should be mounted on the inlet line.

6 Connect the cooler outlet to a discharge or return line.

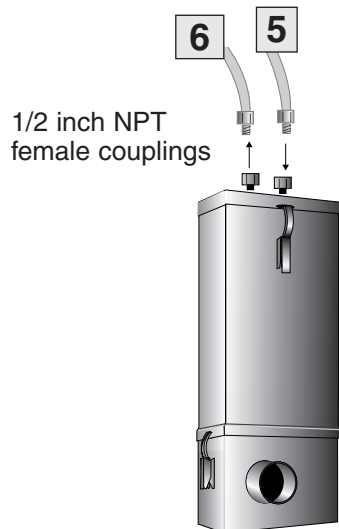

TIP: Make the connections with flexible hose at least 14 inches (35.5 cm) long. This allows you to easily remove the cooler coils for cleaning.

Conair has made the largest investment in customer support in the plastics industry. Our service experts are available to help with any problem you might have installing and operating your equipment. Your Conair sales representative also can help analyze the nature of your problem, assuring that it did not result from misapplication or improper use.

WE'RE HERE TO HELP

To contact Customer Service personnel, call:



From outside the United States, call: 814-437-6861

You can commission Conair service personnel to provide on-site service by contacting the Customer Service Department. Standard rates include an on-site hourly rate, with a one-day minimum plus expenses.

HOW TO CONTACT CUSTOMER SERVICE

If you do have a problem, please complete the following checklist before calling Conair:

- Make sure you have all model, serial and parts list numbers for your particular equipment. Service personnel will need this information to assist you.
- Make sure power is supplied to the equipment.
- Make sure that all connectors and wires within and between control systems and related components have been installed correctly.
- Check the troubleshooting guide of this manual for a solution.
- Thoroughly examine the instruction manual(s) for associated equipment, especially controls. Each manual may have its own troubleshooting guide to help you.
- Check that the equipment has been operated as described in this manual.
- Check accompanying schematic drawings for information on special considerations.

BEFORE YOU CALL ...

Additional manuals and prints for your Conair equipment may be ordered through the Customer Service or Parts Departments for a nominal fee.

EQUIPMENT GUARANTEE

Conair guarantees the machinery and equipment on this order, for a period as defined in the quotation from date of shipment, against defects in material and workmanship under the normal use and service for which it was recommended (except for parts that are typically replaced after normal usage, such as filters, liner plates, etc.). Conair's guarantee is limited to replacing, at our option, the part or parts determined by us to be defective after examination. The customer assumes the cost of transportation of the part or parts to and from the factory.

PERFORMANCE WARRANTY

Conair warrants that this equipment will perform at or above the ratings stated in specific quotations covering the equipment or as detailed in engineering specifications, provided the equipment is applied, installed, operated and maintained in the recommended manner as outlined in our quotation or specifications.

Should performance not meet warranted levels, Conair at its discretion will exercise one of the following options:

- Inspect the equipment and perform alterations or adjustments to satisfy performance claims. (Charges for such inspections and corrections will be waived unless failure to meet warranty is due to misapplication, improper installation, poor maintenance practices or improper operation.)
- Replace the original equipment with other Conair equipment that will meet original performance claims at no extra cost to the customer.
- Refund the invoiced cost to the customer. Credit is subject to prior notice by the customer at which time a Return Goods Authorization Number (RGA) will be issued by Conair's Service Department. Returned equipment must be well crated and in proper operating condition, including all parts. Returns must be prepaid.

Purchaser must notify Conair in writing of any claim and provide a customer receipt and other evidence that a claim is being made.

WARRANTY LIMITATIONS

Except for the Equipment Guarantee and Performance Warranty stated above, Conair disclaims all other warranties with respect to the equipment, express or implied, arising by operation of law, course of dealing, usage of trade or otherwise, including but not limited to the implied warranties of merchantability and fitness for a particular purpose.